

NOTICE: This document contains references to Varian. Please note that Varian, Inc. is now part of Agilent Technologies. For more information, go to www.agilent.com/chem.



Varian, Inc.
2700 Mitchell Drive
Walnut Creek, CA 94598-1675/usa

210-MS, 220-MS, and 225-MS GC/MS Ion Trap Mass Spectrometer

Hardware Operation Manual



All rights reserved including the right of reproduction in whole or in part in any form. This document may be electronically reproduced, distributed, or printed in its entirety, provided this copyright and statement are attached. Any modification or any other reproduction, distribution, or use of this document or portions hereof is strictly prohibited without the express written permission of Varian, Inc.

COPYRIGHT© 2009 Varian, Inc. All rights reserved.

Contents

Introduction.....	5
Functional Description.....	9
Introduction	9
Gas Chromatograph (GC)	11
Mass Spectrometer (MS).....	11
Cooling Fans	11
Vacuum System	12
Transfer Line	14
Ion Trap Assembly	16
Ion Gauge.....	20
Electronic Assemblies	21
Power Input Subsystem and Turbomolecular Pump Controller.....	22
Main Power Circuit (210-MS and 220-MS)	22
Power Board	23
RF Generator Assembly.....	24
Manifold Electronics Assembly	25
Foreline Pump	26
210-MS and 220-MS	26
225-MS.....	26
Data System	27
Computer/Instrument Interface.....	27
Computer Hardware and Software Requirements	27
Autosampler.....	27
Chemical Ionization.....	29
Introduction	29
Installing CI Reagent Gas.....	29
CI Reagent Gas Requirements	30
Setting Up the CI Reagent Gas Supply	30
Checking the Reagent Gas Plumbing for Leaks	32
Setting CI Reagent Flow	33
Default Parameters for Gaseous CI Reagents	33
Default Parameters for Liquid CI Reagents	33
Ion Intensities for Standard CI Reagents	34
Liquid CI Reagents	34
Installing the Liquid CI Inlet.....	34
Filling and Refilling the Liquid CI Reservoir Bulb	37
Preserving Liquids in Reservoirs	37
Setting Flows of Vapor from Liquid CI Reagents.....	38
Switching to Gaseous CI Reagent	39

MS Maintenance	41
Foreline Pump (210, 220-MS only).....	41
Checking Foreline Pump Oil	41
Purging Foreline Pump Oil.....	42
Changing Foreline Pump Oil.....	43
Flushing Pump Oil.....	44
Changing the Oil Mist Cartridge (210, 220, and 225-MS)	44
DS-42 Oil Mist Eliminator	45
DS-102 Oil Mist Eliminator	46
Checking Cooling Fans	47
Replacing the Turbomolecular Pump (210-MS and 220-MS)	48
Replacing the Turbomolecular Pump (225-MS)	50
Servicing the Ion Trap	50
Turning Off the MS	51
Retracting the Transfer Line	51
Removing the Analyzer Assembly.....	52
Replacing the Electron Multiplier	53
Replacing the Filament(s).....	54
Removing the Ion Trap Oven	55
Cleaning the Trap Components.....	56
Disassemble the Trap Components.....	56
Cleaning the Trap Components	57
Cleaning Silica-Coated Electrodes	59
Cleaning the Quartz or Silica-Coated Spacers	59
Reassembling the Trap	59
Reinstalling the Trap Oven Assembly	60
Repositioning the Electron Multiplier	61
Reinstalling the Analyzer Assembly	61
Installing the Transfer Line	61
Closing the Vent	62
Turning On the MS	62
Baking Out the Trap.....	62
Checking the Ion Trap Operation	62
Filling the Calibration Compound Vial	63
Moving the MS.....	63
210-MS or 220-MS.....	63
225-MS.....	64
Troubleshooting	65
Isolating the Problem.....	65
Checking the Data System	65
Checking the GC	65
Checking the MS	65
Resolving Problems with Spectra.....	66
No Spectrum	66
Checking for an Open Filament	67
Checking the Turbomolecular Pump.....	67
Checking the RF Adjustment	67
Checking the Method Parameters	67
Checking the Trap Assembly	68
Checking the Electronics.....	69
Loss of High Mass Peaks	69
Missing Part of the Spectrum	69
Checking the RF Adjustment	70
Checking the RF Storage Level	70

Checking the Trap Temperature	70
Poor Resolution with Acceptable Air and Water Levels	70
Checking the Ion Content of the Trap	71
Checking the Axial Modulation Setting	71
High Baseline at High Masses.....	71
Trap Calibration Fails after Calibration Ions are Identified	72
Checking the Electron Multiplier Voltage	72
Checking the Cal Gas Pressure.....	72
Checking for Leaks.....	72
Setting Up for Leak Checking	73
Removing High Water Levels	77
Using Leak Detection Gas.....	78
Repairing Large Air Leaks	79
Repairing Small-to-Moderate Air Leaks.....	79
Checking GC Connections.....	79
Removing the Capillary Column	80
Installing New Capillary Columns	81
Troubleshooting the GC	82
Running the COLTEST Sample	83
Setting Up the Injector Conditions	83
Setting Up the Column	83
Setting Up the Transfer Line and Trap-Temperature Conditions.....	83
Setting Up a MS Acquisition Method	84
Troubleshooting Chromatographic Problems	85
Documents, Parts, and Supplies	89
Documents.....	89
Parts and Supplies.....	89
Kits, Assemblies, Boards, and Cables.....	89
Trap Components	90
Pump Spares, Pumps, Pump Conversion Parts.....	90
GC Spares.....	91
Tools, Test Samples, and Other Supplies	91
CI Parts/Spares.....	91
Varian Service	92

Introduction

This manual contains hardware information for the Varian 210-MS, 220-MS, and 225-MS Ion Trap Mass Spectrometers. There are five chapters. The first chapter provides a functional description of the mass spectrometer (MS) and details of the instrument subsystems. The next chapter describes the installation and operation of the chemical ionization source. The third chapter contains MS maintenance procedures. The fourth chapter describes troubleshooting procedures. The final chapter provides information about related documents, instrument parts, and contacting Varian, Inc.

The following identifies the components of the ion trap MS with the top cover off.

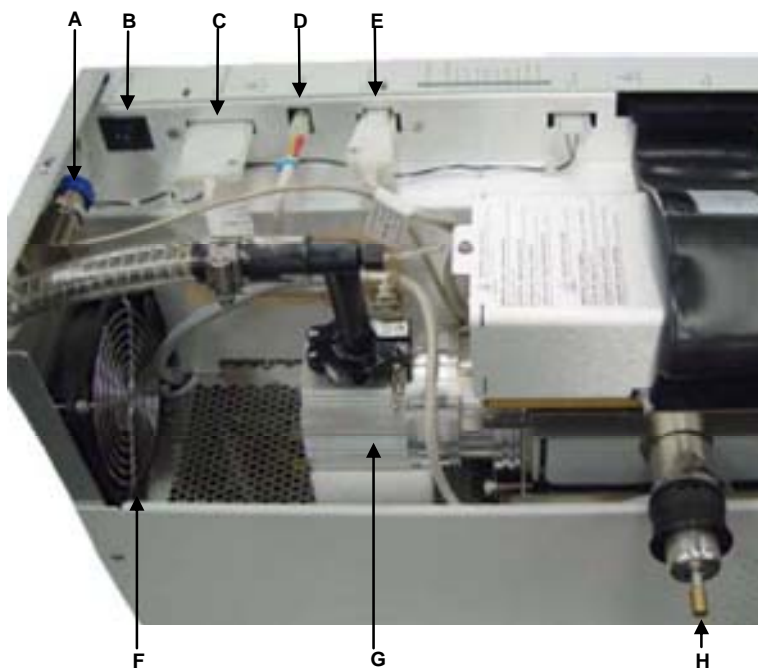

210-MS and 220-MS Top View

A	Chemical Ionization (CI) Shutoff Valve	E	Manifold Heater
B	Service Switch	F	Cooling Fan (1 of 2)
C	Transfer Line Heater	G	Turbomolecular Pump
D	Trap Heater	H	Transfer Line

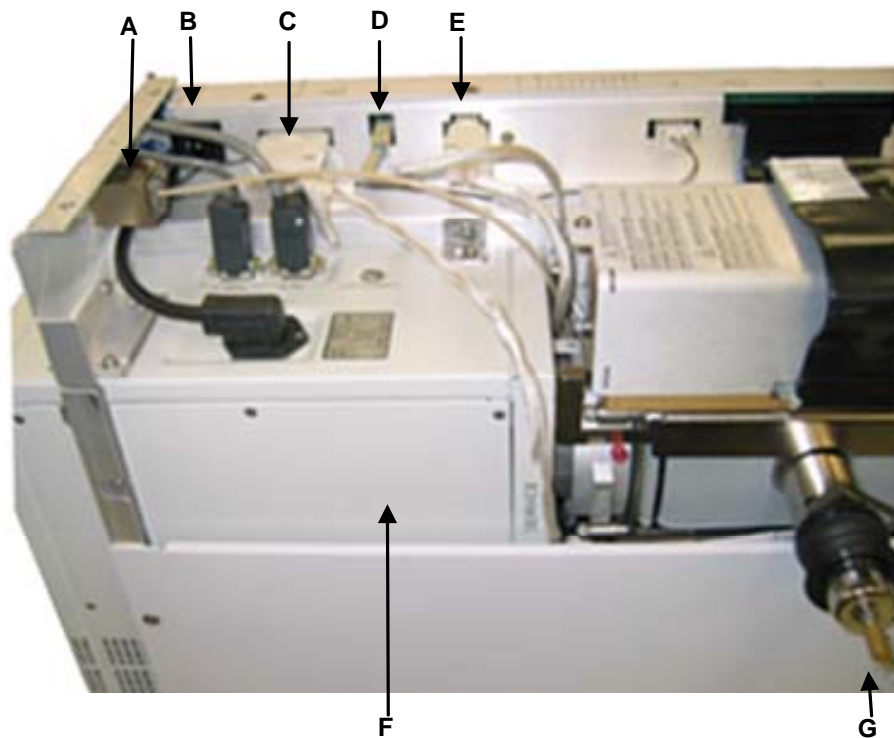

225-MS Top View

A	Chemical Ionization (CI) Shutoff Valve	E	Manifold Heater
B	Service Switch	F	Integrated Pumping Solution
C	Transfer Line Heater	G	Transfer Line
D	Trap Heater		

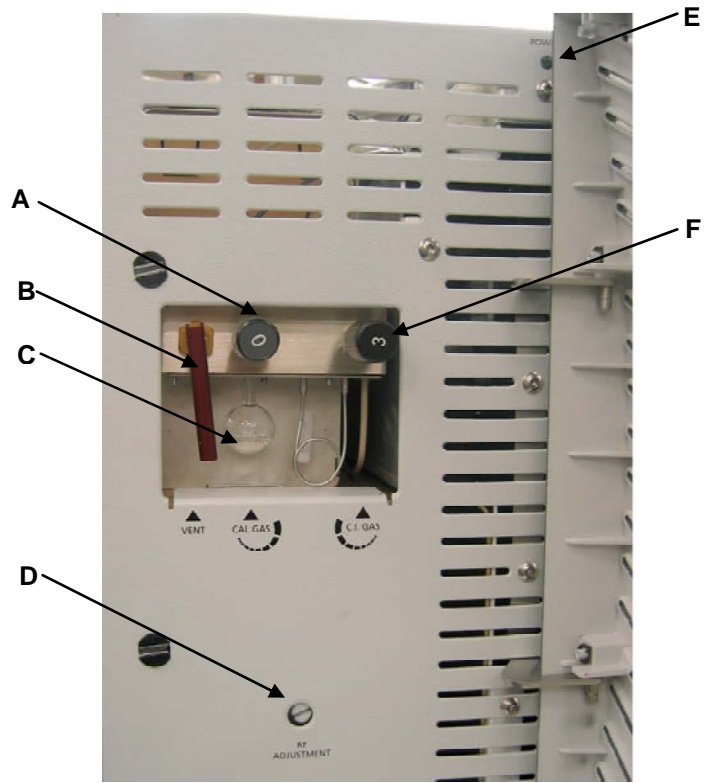

210-MS, 220-MS, and 225-MS Front Panel

A	Cal Gas Adjust	D	RF Coil Adjustment Screw
B	Vent Valve	E	Power Switch LED
C	Cal Gas Vial	F	CI Cal Gas Adjust

Functional Description

Introduction

The 210-MS, 220-MS, and 225-MS GC/MS systems have four principal components:

- Gas chromatograph (GC)
- Mass spectrometer (MS)
- Data system (DS)
- Autosampler (optional)

The following figure is a block diagram of the 210-MS, 220-MS, and the 225-MS. A short, transfer line connects the GC and MS. The autosampler sits on top of the GC.

Samples are injected manually or using the autosampler onto the capillary column through the GC injection port. The gas chromatograph separates the sample molecules. Effluent from the GC enters a fused silica capillary column, which goes through the transfer line and into the ion trap. The sample molecules undergo electron or chemical ionization before being analyzed according to their mass-to-charge ratios.

The ions are detected by an electron multiplier, which produces a signal proportional to the number of ions detected. The electron multiplier passes the ion current signal to the system electronics, which in turn amplify the signal, digitize the result, and pass it on to the data system for further processing and display. See the figures that follow this one.

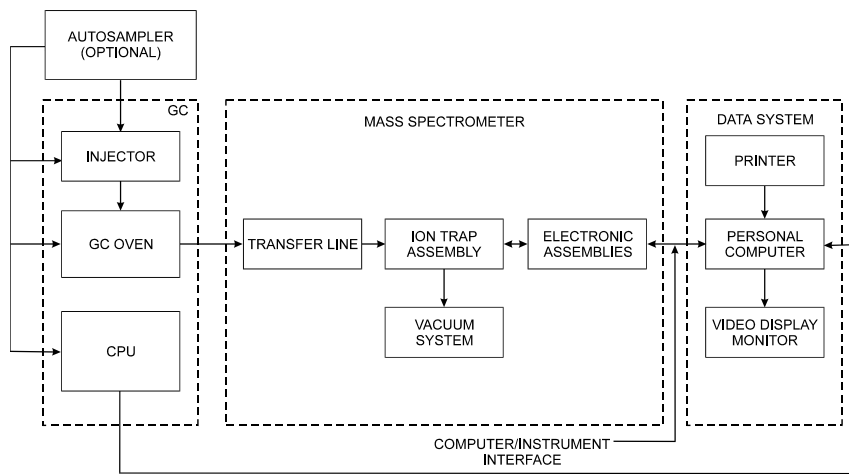

Block Diagram of the 210-MS, 220-MS, and 225-MS

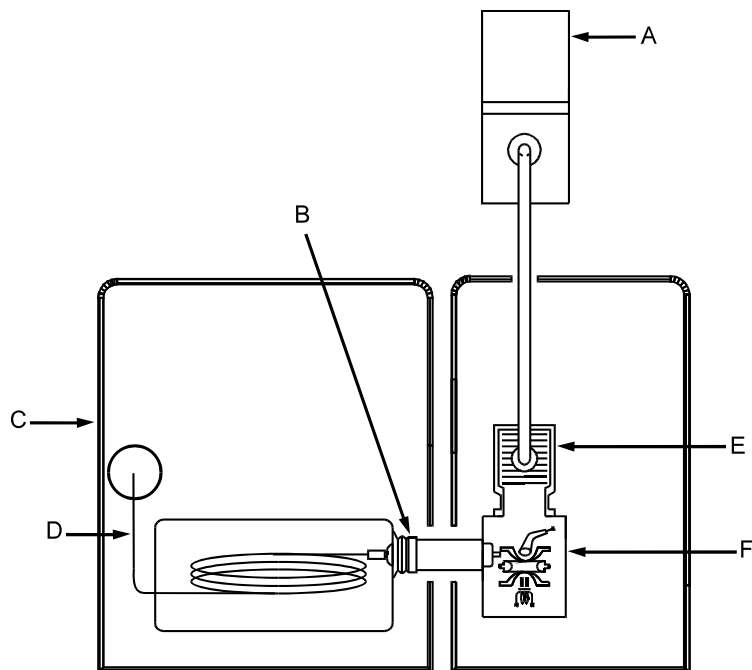

A	Foreline Pump	D	Capillary Column
B	Transfer Line	E	Turbomolecular Pump
C	GC Oven	F	Ion Trap Assembly

Principal Components of 210-MS and 220-MS (Top View)

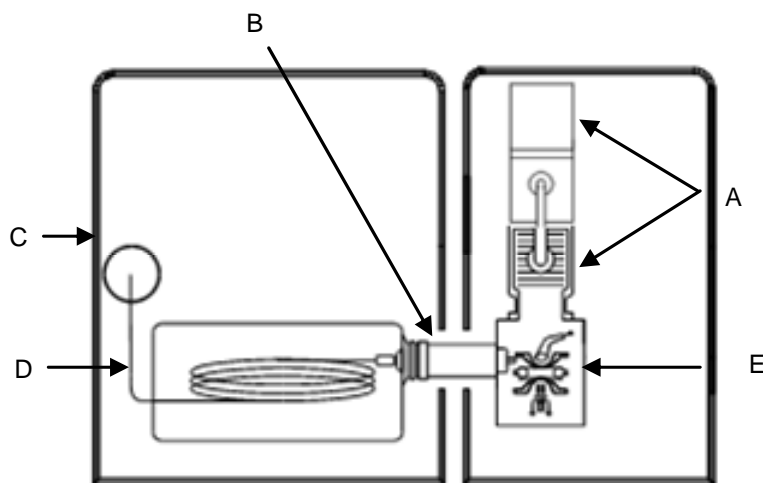

A	Integrated Pumping Solution	D	Capillary Column
B	Transfer Line	E	Ion Trap Assembly
C	GC Oven		

Principal Components of 225-MS (Top View)

Gas Chromatograph (GC)

Either the 431-GC or the 450-GC is part of the GCMS system. For more details about the GC, see the Varian 450-GC User Manual, part number CP501411 or the Varian 430-GC and 431-GC User Manual, part number CP501406.

Mass Spectrometer (MS)

These GCMS systems are ion trap systems, which consist of mechanical and electronic assemblies.

The instrument is separated into the electronics and the analyzer compartments. The electronics compartment includes the following:

- Controller board
- Power board

The analyzer compartment includes the following:

- Transfer line
- Vacuum manifold, which includes the ion trap
- Vacuum pump, controller, and turbo power supply
- RF coil and generator
- Pneumatics manifold
- Manifold Board
- Integrated Pumping Solution (225-MS only)

Cooling Fans

Two fans mounted on the rear panel of the spectrometer cool the unit. The analyzer compartment fan draws air from the back, blowing it directly on the bearing end of the turbomolecular pump in the analyzer compartment. The air then flows past the manifold electronics and out the front of the instrument. The turbomolecular pump controller supplies power to the analyzer compartment fan.

The electronics section fan draws air from the back and blows it across the controller and power boards in the electronics compartment.

To prevent hot air from the GC oven from affecting the MS, ensure that the

- 210-MS or the 220-MS is at least 15.3 cm (6 in.) away from a wall
- 225-MS is at least 25.4 cm (10 in.) away from a wall

Hot air from the GC oven does not affect the MS as long as the system is at least six inches from a wall. The power board supplies power to the electronics compartment fan.



To prevent overheating, do not block cooling fans air intakes.

Vacuum System

The vacuum system evacuates water vapor, air, and carrier gas from the MS ion trap assembly. Principal vacuum system components include

- Vacuum manifold
- Turbomolecular pump
- Foreline pump
- Vent valve
- Cal gas valve
- Chemical Ionization (CI) reagent gas valves

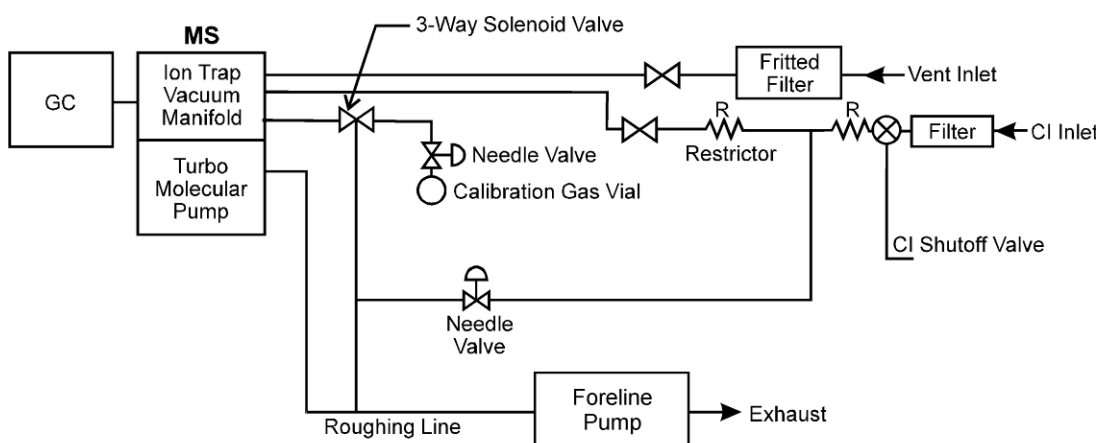

210-MS and the 220-MS Vacuum System Diagram

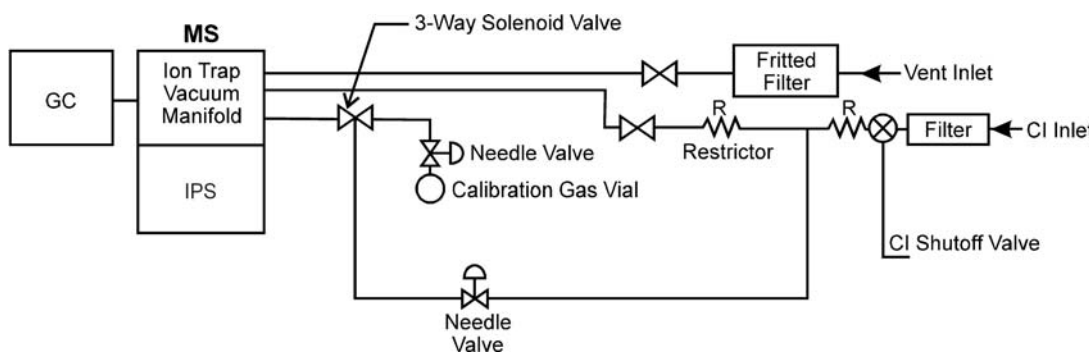

225-MS Vacuum System Diagram

Vacuum Manifold

The vacuum manifold encloses the ion trap assembly. The vacuum manifold is a stainless-steel tube, which houses the analyzer. The turbomolecular vacuum pump, which evacuates the manifold, discharges into a foreline pump for the 210-MS and the 220-MS. The 225-MS has the integrated pumping solution, which includes the turbomolecular and the foreline pumps.

The vacuum manifold sits on top of the RF coil housing. The turbomolecular pump makes an airtight seal with the manifold, with a Viton® O-ring. The ion trap assembly, which is suspended from the analyzer flange, extends into the body of the manifold. Another Viton® O-ring makes an airtight seal between the manifold and the analyzer flange. Quick release tabs permit easy removal of the trap in the absence of vacuum.

Eight electrical feed-throughs pass through the analyzer flange:

- One for the electron gate
- Three for the filament assembly
- Two for the axial modulation voltages applied to the filament and multiplier end cap electrodes of the ion trap assembly
- One for the high voltage to the electron multiplier cathode
- One for the ion current signal from the electron multiplier anode

A feed-through that passes through the underside of the manifold, provides radio frequency (RF) voltage to the ring electrode.

An ion gauge monitors the pressure inside the manifold by generating and collecting ions from any gas present. The ion gauge also passes through the analyzer flange.

The four additional vacuum manifold functions are:

- Transfer line
- CI reagent gas
- Introduction of the cal gas
- Venting

Turbomolecular Vacuum Pump

A turbomolecular vacuum pump provides the high vacuum for MS. Under normal operating conditions, this pump provides a vacuum of approximately 10^{-5} Torr (1.33×10^{-3} Pa) in the manifold region outside the ion trap assembly. The pump, which is rated at 80 liters/second, operates at 60 liters/second. It is air cooled and thermostatically protected. If the temperature of the pump housing near the bearing exceeds 60 °C, the pump automatically shuts down.

The turbomolecular pump controller regulates and supplies power to the pump. Turning off the main power switch on the rear panel of the MS shuts off power to the turbomolecular-pump controller and foreline pump.

NOTE: The electronic service switch does not control the vacuum pumps.

The turbomolecular-pump controller monitors the rotational speed. Monitor the turbomolecular pump speed from the software.

If the speed of the turbomolecular pump is equal to or greater than 92% of the maximum operating speed, the signal from the controller prompts the power control board to send a TURBOMOLECULAR SPEED OK signal to the controller board. The controller board uses the signal to enable or disable the filament, electron multiplier voltage, RF generator, Chemical Ionization (CI) reagent gas valve, and cal gas valve by means of an electronic interlock.

If the pump speed falls below 92% of its maximum operating speed, the TURBOMOLECULAR SPEED OK signal to the controller board turns off. The filament, electron multiplier, RF generator, CI reagent gas valve, and cal gas valve turn off automatically. This indicates a major air leak in the system or that the pump is too hot.

Pneumatics Manifold

The pneumatics manifold is an aluminum block mounted to the front of the vacuum manifold. It has two solenoid and two needle valves for the cal gas, and CI cal gas, the cal gas vial, and the vent valve.

The vent valve, which is manually operated, connects to the atmosphere through the pneumatics manifold. A toggle arm on the front of the instrument opens and closes the vent valve.

The calibration-gas-valve assembly consists of a metering needle valve, an ON/OFF solenoid-operated valve, and a glass vial containing the calibration liquid. The assembly sits directly behind the instrument's door. The needle valve controls cal gas flow into the vacuum manifold through the solenoid valve.

The calibration compound is perfluorotributylamine (PFTBA) or $C_{12}F_{27}N$, also known as fluorocarbon-43 (FC-43). A small glass vial attached to the valve assembly holds the compound. You set the flow of cal gas into the manifold manually using a needle valve. The data system controls the opening and closing of the solenoid-operated valve.

Two solenoid valves control the flow of CI reagent gas into the manifold. The shutoff valve, which is near the rear panel, opens to let reagent gas flow into the instrument. The foreline pump removes a portion of the CI gas to prevent CI gas surges (pressure pulses). The gas flows through the shutoff valve through metering and solenoid operated valves before entering the vacuum manifold. The CI needle valve determines the split ratio of the reagent flow between the manifold and foreline pump.

Turn the CI reagent gas valve on and off using System Control or Acquisition. Adjust the flow rate of the reagent gas into the manifold by means of a metering valve.

Transfer Line

A stainless steel tube transfer line couples the GC to the MS. The transfer line keeps the GC column warm as the column enters the MS. The transfer line is 12 cm (5 in.) long, and has a diameter of 4.1 cm (1.6 in.). One end enters a hole in the right side of the GC before passing into the GC oven. The transfer-line tip enters the vacuum manifold and goes into the ion trap.



**WARNING:
BURN HAZARD**

The transfer line is hot. Ensure it is cool before touching it, or use protective gloves.

The transfer line is a stainless-steel weldment fitted with a center tube, a heat exchanger, and a boot. The heat exchanger, an aluminum cylinder, contains a cartridge heater and a thermocouple as the temperature sensor. The temperature sensor measures the temperature of the line. The cartridge heater heats the cylinder, which distributes heat evenly throughout the transfer line. The

boot of the transfer line, which attaches to the GC, prevents hot air leakage from the GC oven.

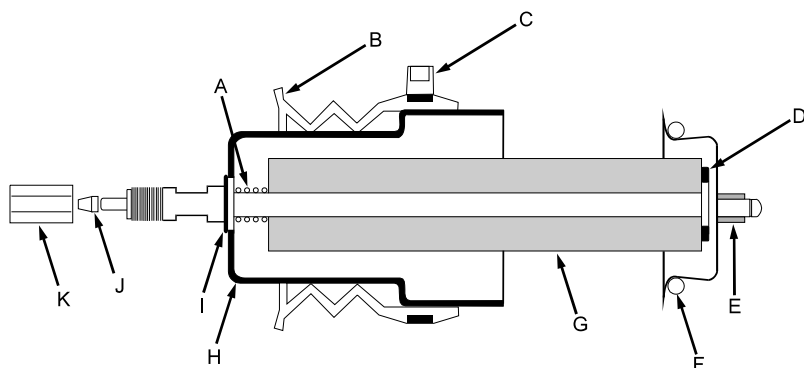

A	Spring	G	Heat Exchanger
B	Boot	H	Nose
C	Tie Wrap	I	E-Ring
D	Washer	J	Ferrule
E	Transfer Line Tip	K	Nut
F	O-Ring		

Transfer Line

A bayonet mount secures the transfer line. Before removing the trap, push the bayonet mount gently as you twist it counterclockwise and pull it out. Make sure the transfer line extends out from the trap.

NOTE: Not removing the transfer line before removing the trap may damage the trap heater post, quartz ring, or the transfer line tip or all.

The power board supplies power to the cartridge heater through a transfer line heater cable. The heater cable projects out from one end of the transfer line. It plugs into a connector on the top of the power board panel.

Set the transfer line temperature from the Temperature view in System Control. The maximum temperature of the transfer line is 350 °C; the minimum temperature depends on the GC oven and trap temperatures. In general, set the transfer line temperature as much as 30 °C below the maximum column operating temperature and not observe adverse chromatographic effects, such as, retention time shifts or peak broadening.

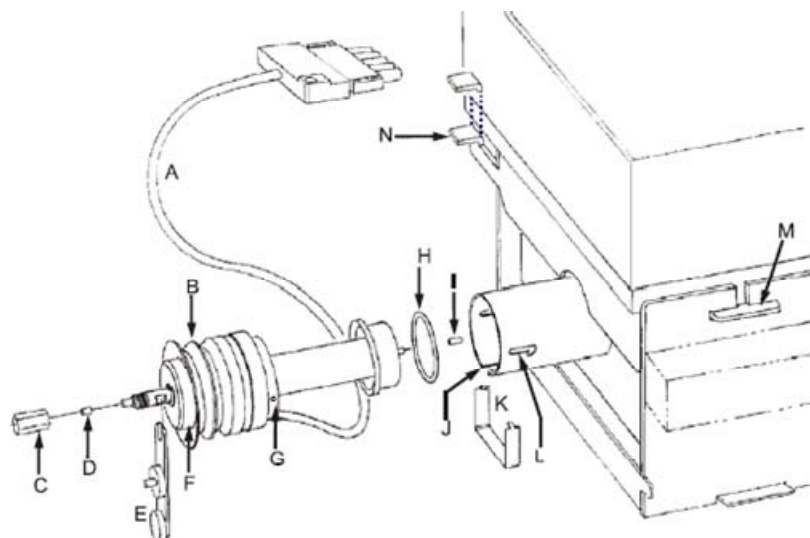

A	Heating Cable	H	O-ring
B	Boot	I	Transfer Line Tip
C	Nut	J	Heating Cable Slot
D	Ferrule	K	Nose Clip
E	Transfer Line/Alignment Tool	L	Bayonet Mount
F	Nose	M	Analyzer Assembly Tongue
G	Nose Hole	N	Analyzer Assembly Lock-Down Tabs Note: The tabs may be long or short

Transfer Line Assembly

Ion Trap Assembly

The ion trap assembly consists of the following:

- Trap oven
- Filament assembly
- Electron gate
- Ion trap electrodes (3)
- Quartz rings (2)
- Electron multiplier assembly

The following figure shows the ion trap assembly with its three electrodes, electron gate, and filament lens.

NOTE: The Silica-Coated Spacers have a shiny finish on the inside surface.

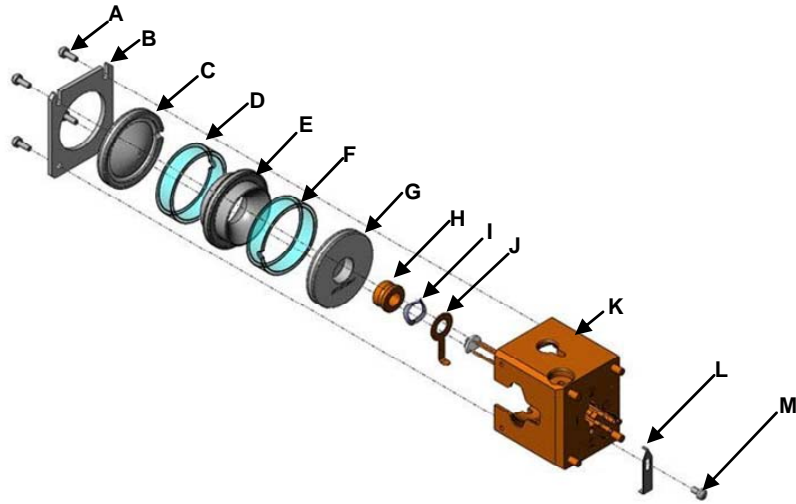

A	Screw, 6/32, 4 places	H	Wave Washer
B	Clamping Plate	I	Gate Conductor
C	Exit-End Cap	J	Trap Oven, "T" is located this side.
D	Quartz or Silica-Coated Spacer, 2 places	K	Filament Assembly
E	RF Ring Electrode	L	Filament Clip
F	Filament (entrance) End Cap	M	Screw
G	Electron Gate		

Ion Trap Assembly

Trap Oven

The trap oven is a heated anodized aluminum block that maintains a uniform temperature for the trap electrodes. A heater post on the manifold flange generates the heat. A thermal well measures the oven temperature. The oven holds the ionization filaments and acts as a lens for focusing the ionizing electrons before they enter the trap.

Filament Assembly

The filament assembly is in the trap oven. It is connected to three feed-throughs on the manifold flange.

The filament assembly consists of two filaments and a repeller plate. The two filaments are mounted side-by-side, with each filament approximately equidistant from the entrance hole of the oven's electron focusing lens. The MS only uses one filament at time; the extra filament is a back up in case the first one burns out.

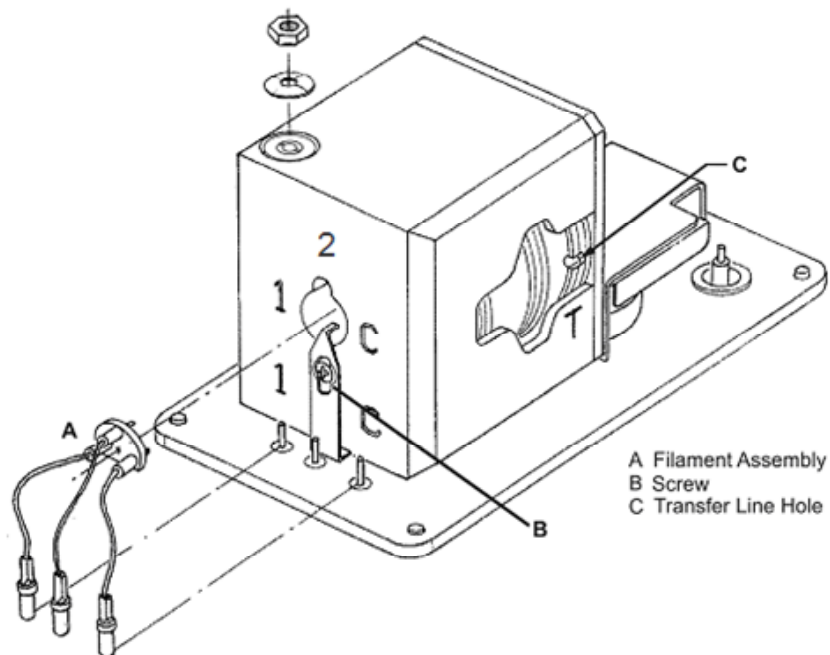

Filament Assembly with Ion Trap

Each filament is a rhenium wire. When heated by electric current, the filament produces electrons by thermionic emission. The filament emission current refers to the flow of emitted electrons from the filament. The magnitude of the filament emission current is set in Instrument Control and current settings range from 5 to 100 μA .

NOTE: The two filaments will probably not have the same net flow of electrons into the ion trap. Therefore, the signal amplitudes from two different filaments will be different. A typical difference is 2:1, but it may be as high as 5:1.

Electron Gate

The electron gate is a cylindrical electrode that controls the entry of electrons into the ion trap cavity. When electrons emitted from the heated filament are not required for ionization, the electron gate is held at a -150V dc potential. The electron gate sits inside the trap oven, in front of the lens and behind the entrance-end cap electrode. An anodization layer insulates it from the filament-end (entrance) cap.

When the ion trap requires electrons, the electron gate potential changes from -150 to +150V dc. The gate potential remains positive for a variable length of time, e.g., from 10 μsec to 65 msec. During this interval, the electrons are focused into the ion trap cavity with sufficient energy, usually, 50 to 80 eV, to achieve electron ionization of the sample molecules, or of the reagent gas molecules in the case of chemical ionization.

Ion Trap Electrodes

The ion trap assembly has three stainless steel electrodes:

- Filament (entrance) end cap electrode
- Exit-end cap electrode
- RF ring electrode

The filament-end cap, exit-end cap, and RF-ring electrodes have hyperbolic inner surfaces. Together, these electrodes form a cavity in which ionization, fragmentation, storage, and mass analysis take place.

Energetic electrons enter the ion trap cavity through the filament-end cap using the electron gate.

There are seven holes in the center of the exit-end cap electrode. Sample ions produced in the ion trap are ejected through these holes into the electron multiplier.

Two identical quartz or silica-coated spacers separate the central ring electrode from the filament and exit-end cap. The trap oven and its clamping plate hold the electrodes and spacers in place. A cutout is provided in the quartz spacers and in the exit-end cap to allow the transfer line to enter the ion trap.

The RF generator assembly provides high voltage RF that is applied to the RF ring electrode.

Under the proper RF voltage, the ion trap electrodes create a three-dimensional, hyperbolic electric field. This field is capable of trapping the ions in stable, aperiodic orbits. As the RF voltage increases, however, the ion trajectories become unstable in increasing order of mass per charge. The ion trap ejects the ions and sends them to an electron multiplier for detection.

During mass analysis, a supplementary RF voltage of 485 kHz is applied to the filament- and exit-end caps. This voltage, termed the axial modulation voltage, improves spectral mass resolution and analytical sensitivity. Other voltages may be applied between the end caps to implement such options as CI and MS/MS.

Electron Multiplier

The electron multiplier is at the exit-end cap electrode. It is in a pre-aligned position on a protective metal clip and can be replaced easily. The multiplier detects positive ions as the ion trap ejects them through the holes in the exit-end cap electrode. The continuous dynode electron multiplier consists of a lead-oxide/glass, funnel-like resistor. A negative voltage of between -800 and -3000V is applied to the front end of the electron multiplier, which is the cathode. The back end of the cathode is held at ground potential, and is the anode.

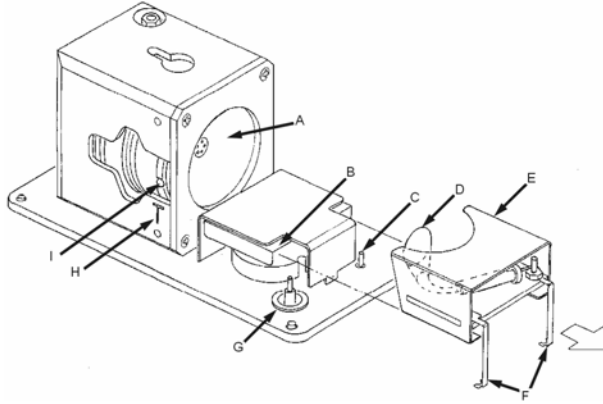

A	Exit-End Cap	F	Multiplier Contacts
B	Electron Multiplier Track	G	Multiplier High Voltage Pin
C	Multiplier Signal Pin	H	Transfer Line Alignment
D	EM Grid	I	Transfer Line Entrance Hole
E	Electron Multiplier Mount		

Position of the Electron Multiplier Relative to the Ion Trap

The negative voltage applied to the cathode attracts the positive ions ejected from the ion trap cavity. These ions strike the cathode with sufficient velocity to dislodge electrons from the inner curving surface of the cathode. The increasingly positive potential gradient draws the ejected electrons into the electron multiplier, further accelerating them in the process. Because the electron multiplier is curved, the ejected electrons strike the inner surface of the multiplier again, and more electrons are emitted. This configuration produces a cascade of electrons that is accelerated toward ground potential at the exit-end of the cathode.

The anode collects the electrons, and passes the resulting ion current signal to the integrator circuit on the lower manifold board. The ion current signal is proportional to the total number of electrons that the ion trap ejects. Typically, the voltage applied to the electron multiplier is adjusted until the gain is about 10^5 . Therefore, each ion that enters the electron multiplier generates approximately 10^5 electrons.

Ion Gauge

The optional ion gauge is based on the Bayard-Alpert gauge tube. The specifications for the gauge are commercially available gauges. Fixed pressure readings with nominally identical gauges may exhibit variations of $\pm 15\%$. The gauges usually have an accuracy of $\pm 25\%$ in mid-range

In general, the ion gauge has good repeatability. However, the ion gauge response depends on gas composition. A certain pressure of air and water give a different reading than that of Helium. The ion gauge is a rough indicator of vacuum conditions. It is not a precise quantitative tool.

The gauge uses thoria-coated iridium (ThO-Ir) filaments. These filaments are burnout resistant, and therefore exhibit high tolerance to air and water in the vacuum manifold. There is a time delay associated with heating the filament. This

delay translates to a delay in determining whether a filament is open. To obtain a stable reading, wait 15 to 20 seconds after the filament is turned on.

The ion gauge measures pressures between 10^{-6} and 10^{-2} Torr. A logarithmic amplifier amplifies the collector current, and the data system interprets this current as measured vacuum.

Electronic Assemblies

The electronic assemblies consist of the following:

- Power input subsystem and turbomolecular pump controller
- Power board
- MS Controller board
- Manifold electronics assembly
- RF generator board and RF coil.

The placement of the electronics minimizes the cable lengths between critical components. The MS controller and power boards are in an electronics enclosure separated from the analyzer section by a sheet metal bulkhead. The manifold electronics are enclosed above the analyzer. The RF generator attaches to the rear of the RF coil assembly.

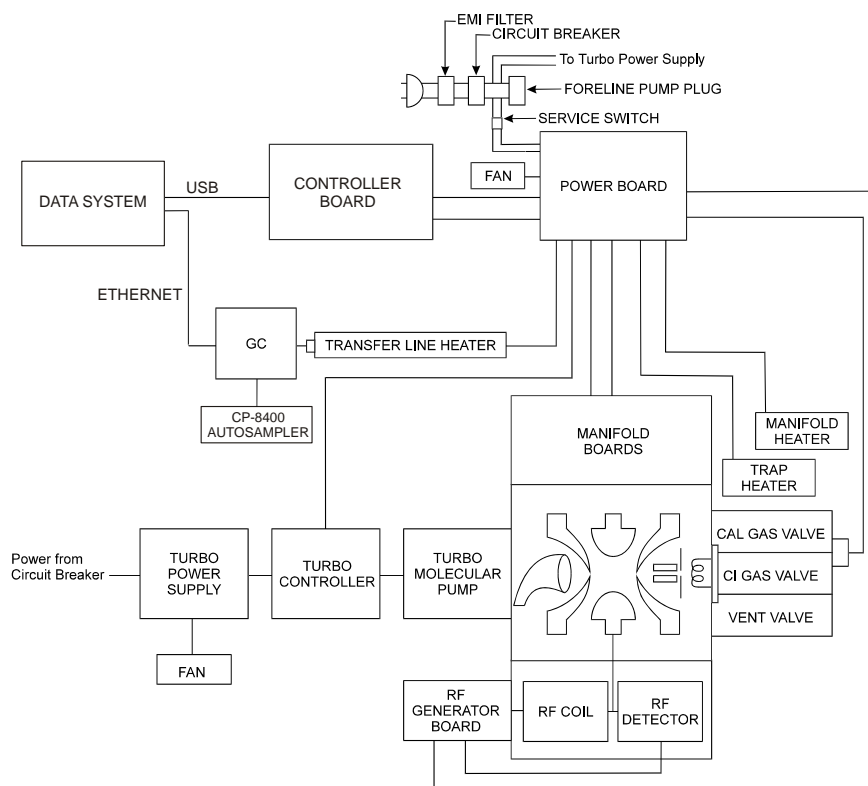

The 210-MS and the 220-MS Electronic Assemblies

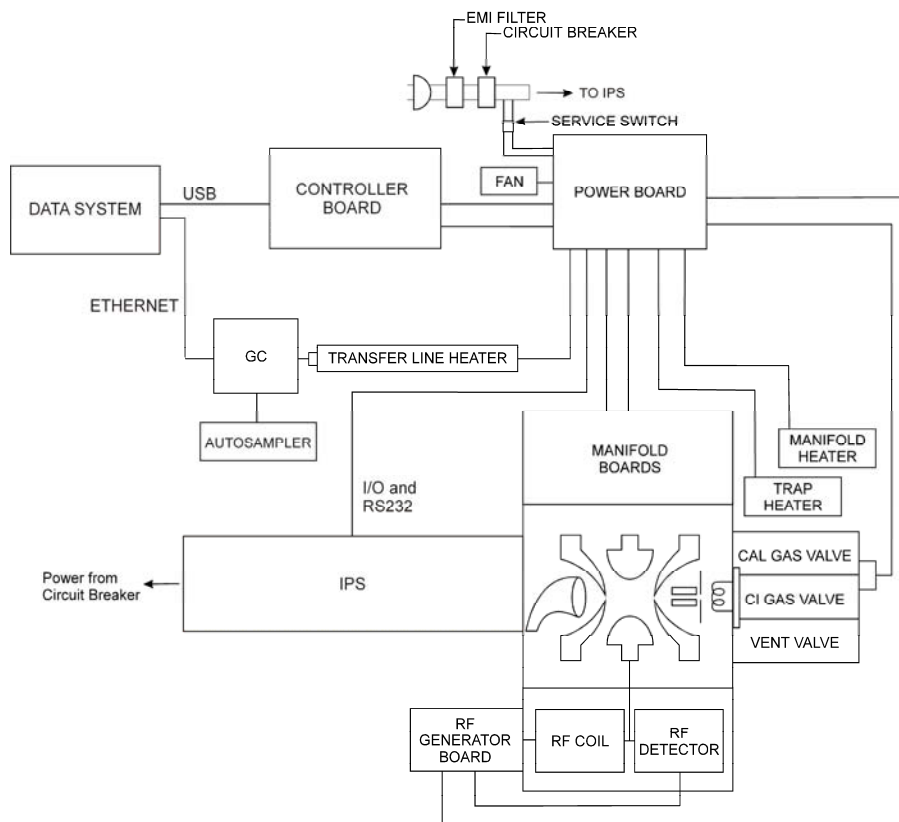

The 225-MS Electronic Assemblies

Power Input Subsystem and Turbomolecular Pump Controller

The power input subsystem contains the following circuits and switches:

- MAIN POWER switch
- Service switch
- Line voltage selector switches

Main Power Circuit (210-MS and 220-MS)

The power line enters the rear panel of the MS, and passes through the line filter and the circuit breaker. After the circuit breaker, the power splits in two directions. One path supplies the turbomolecular pump controller, power controller, and foreline pump. The second path goes to the electronics service switch, which controls power going to the power board. The electronics service switch allows the vacuum to be maintained if the electronics need servicing.

The power board controller has the selector switch for the line voltage, which is set at the factory.

NOTE: The MS cannot be switched from 115V to 220V without also changing the transfer and manifold heaters.

The turbo controller regulates the speed of the turbo pump. The controller provides turbo speed and startup power to the power board. The +24V dc power supply supplies power for the solenoid valves, electronics compartment fan, and the electron multiplier power supply.



**WARNING:
SHOCK HAZARD**

In the event of an emergency, shut off all power to the MS by turning the main power switch OFF.

Power Board

The power control board supplies power to all electronics components except the turbomolecular controller. It controls the heaters, ion trap and ion gauge filaments, and solenoid valves.

NOTE: The switching power supply is protected by a 5A, non-time-delay fuse.

The following switching power supplies are on the board:

- The + 5V dc power supply provides voltage to all digital circuits.
- The -15V and +15V dc power supplies provides voltages to the analog circuits on the power board and the manifold electronics assembly.
- The +20V and -20V dc power supplies provides the voltages to the controller and RF generator board's analog circuitry.
- The +60V dc power supply, provides unregulated +60V dc voltage to the RF generator board and trap heater.
- The +180V and -180V dc power supply provides voltage to the ion trap electron gate circuit and the ion gauge.

The following circuits are on the board:

- The trap and ion gauge filament control circuits that provide current to heat the filament and regulate the emission current from the filament. The trap-filament emission current is set between 5 and 100 μ A.
- Three heater control circuits that provide feedback control for the manifold, trap, and transfer-line heaters. The trap heater uses a proportional integral (PI) control circuit.
- Three solenoid control circuits that turn the cal gas, CI reagent gas, and CI shutoff valve solenoids on and off.
- The electron energy control circuits that controls the dc bias on both the ion trap and ion gauge filaments.
- The diagnostic multiplexer circuit that routes the voltage output of various components, and circuits on the power control board to the controller board.
- On the top edge of the power board are 12 monitor LEDs. When illuminated, these lights indicate that the voltages of the various circuits on the power board are at the correct levels, and that there are no faults. In idle mode, all LEDs, except the +180V, -180V, and trap filament are on. The LEDs for +180V, -180V, and the trap filament only turn on when the filaments are on.

RF Generator Assembly

The RF generator assembly consists of an RF generator circuit board, an RF detector circuit board, and the RF coil. A shielded housing beneath the vacuum manifold encloses the coil and RF detector circuit board. The RF generator circuit board is attached to the back of the shielded housing.

The RF generator circuit board receives an analog signal from the controller board that is proportional to the current mass position in the scan, which is in turn proportional to the RF voltage applied to the ion trap. The RF detector circuit board sends a signal to the RF generator; this signal is proportional to the actual amount of RF voltage applied to the ion trap. The RF generator board compares the desired and actual RF voltages, and based on this feedback, adjusts the gain to modify the applied RF voltage amplifier to equal the desired RF voltage level. Since the high voltage required by the ion trap exceeds the capabilities of conventional electronic amplifiers, a resonant LC (inductor-capacitor) circuit consisting of the RF coil and the ion trap capacitance is used. At resonance, the RF voltage at the ion trap-end of the coil is about 100 times that at the RF generator circuit end of the coil.

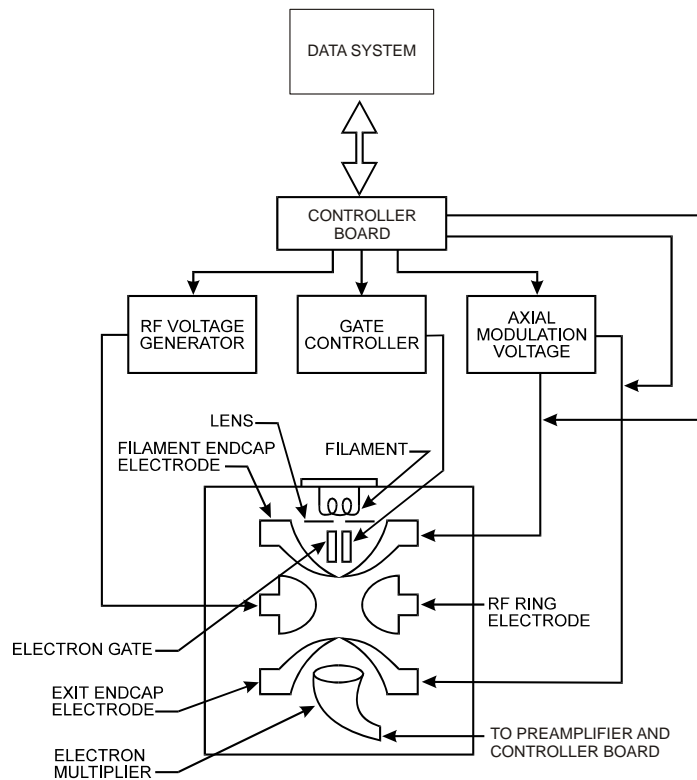

Ion Trap Assembly

Manifold Electronics Assembly

Two boards are enclosed atop the analyzer flange. These boards have the following circuitry, which is critical to the functioning of the ion trap.

- The electron multiplier power supply provides high voltage (-800 to -3000V dc) to the cathode of the electron multiplier.
- The integrator circuit, which receives the amplified ion current from the anode of the electron multiplier, converts the current into voltage, for example, 10^{-7} A into 1.0V, and passes the voltage on to the controller.
- The trap filament selection relay.
- The electron gate control controls the gate polarity.
- The axial-modulation low- and high-frequency transformers and amplifiers.
- The ion gauge support circuitry, which includes filament On/Off and selection relays and a log amplifier for gauge read-back signal conditioning.

MS Controller Board

The controller board controls the MS. The controller board communicates with the data system using the USB interface of the data system computer. The MS controller performs the following functions:

- Interprets instrument commands from the data system and produces a sequence of analog and digital signals that control the operation of circuits on other MS boards
- Collects analog and digital diagnostic data from other subsystems and transmits that information to the data system
- Filters, integrates and digitizes the ion current signal, and transmits the spectra to the data system
- Generates axial modulation waveforms, including waveforms used by CI, MS/MS, and SIS options

When powered up, the controller's processor runs a ROM resident program that initializes the board. The program permits the processor to receive information through the USB interface. When the data system is started, operating information downloads to the RAM memory of the controller board. The controller board then performs in response to the commands sent through the USB interface.

NOTE: The controller board is accessed through two connectors on the rear panel of the instrument.

J42 is a USB connection that the Data System.

J43, a D-shell connector labeled, Remote Option, is a special research application and the GC start signal.

When a mass spectrum is acquired, the data system downloads parameters, such as, electron multiplier voltage, scan range, and time, and ionization mode. This information is used to create a scan over the desired mass range. At the end of the scan, the data is sent to the data system for further processing and display.

The waveform generator can create waveforms over a wide range of frequencies and amplitudes. The waveform generator has the following:

- Dual-port RAM (256 Kbytes) to provide memory for single or multiple digitized waveforms.
- A selectable frequency generation clock (625 KHz, 1.25 MHz, or 2.5 MHz and a 15-bit variable-length counter to control timing.
- A 12-bit DAC, low-pass filter and amplifier to reconstruct waveforms.
- A variable operational frequency range that uses the high frequency transformer (12 to 500 KHz) or the low frequency transformer (200 Hz to 1.25 KHz).
- Two transformers, that apply the waveform output to the end cap electrodes.

NOTE: The waveform options, for example, CI, MS/MS, or SIS, require the waveform key(s). The key(s) is installed by the factory, or by a Varian Customer Support Representative.

Foreline Pump

The foreline pump has two purposes. The first is reducing the vacuum system pressure to a level that permits the operation of the high vacuum turbomolecular pumps. The second is maintaining the vacuum system pressure by removing the exhaust gases of the high vacuum pump.

210-MS and 220-MS

For the 210-MS and the 220-MS, the foreline pump is connected to the turbomolecular pump by vacuum tubing. The pump plugs into the rear panel outlet labeled, J2 - LINE VOLTAGE - PUMP ONLY, on the rear of the MS. Power is supplied through this outlet and is controlled by the power switch on the rear panel. The foreline pumps are two-stage rotary vane pumps with pumping speeds of 45 L/min.



WARNING:
CHEMICAL HAZARD

If you use the 210-MS, 220-MS, or 225-MS to analyze hazardous materials, you must have an exhaust system for the foreline pump that complies with applicable safety and environmental regulations.

225-MS

The 225-MS has a foreline pump integrated into the module and does not need an external vacuum line or a power connection on the rear panel.

Data System

The data system (DS) has both hardware and software components.

The hardware includes a computer/instrument interface, personal computer, video display monitor, and optionally, a printer.

The software installed on the system includes programs that control the MS, that control the GC, that set system parameters automatically, and that oversee scan-control, data-acquisition, and data processing

For a complete description of software, refer to the *MS Workstation Software Reference Manual*.

Computer/Instrument Interface

The GCMS uses a universal serial bus (USB) interface. The USB is a standard computer/instrument communications link for all types of computers.

Computer Hardware and Software Requirements

The Varian web site lists compatible computer hardware and software. The following is a link.

http://www.varianinc.com/cgi-bin/nav?products/chrom/gcms/msws_computer_req

Autosampler

The autosamplers available are the Varian 8400, 8410, and CombiPAL AutoSamplers. For complete installation and operating instructions, please refer to the autosampler manual.

Chemical Ionization

Introduction

NOTE: CI mode is an MS option. If your system does not have this option, you cannot perform CI analyses.

Chemical Ionization provides mass spectral data that complement electron ionization (EI) data for the analysis of complex compounds. In the standard CI mode of operation, a CI reagent gas is introduced into the ion trap analyzer from an external gas supply cylinder. The reagent gas is ionized by EI to form reagent ions. These reagent ions then ionize sample molecules that enter the ion trap with the helium carrier gas from the capillary column. The operation and adjustment of reagent gases for the standard CI option are described in the first part of this section.

Two additional options allow the selection of certain liquids as sources for CI reagents. These are the Liquid CI Inlet (or LCI Inlet) and the Multiple CI module (or MCI module). This chapter describes how to install and operate the LCI inlet. Refer to the documentation included with the MCI module for installing and operating the module.

Installing CI Reagent Gas

Before evacuation, new gas lines contain a significant amount of adsorbed water vapor. The longer the gas line, the more adsorbed water and the longer pumping time required to evacuate water from the line. To minimize this pumping time, the line must be as short as possible. Make sure, however, that the gas line is long enough to reach the rear of the MS and can accommodate the movement of the MS 9 inches (23 cm) to the right (for access to the transfer line and turbomolecular pump).

Do not store gas cylinders or lecture bottles where they can damage cables or gas lines, and secure them in accordance with standard safety practices. Lecture bottles have rounded ends and require a support (for example, Matheson Model 505 Non-Tip Stand).

Before installing the CI reagent gas supply, complete the following procedures:

- Tune the instrument in EI mode
- Check the entire system for leaks

CI Reagent Gas Requirements

Although the requirements for methane, isobutane, and ammonia as CI reagent gases are stated here, other CI reagent gases can be used.

Use a high-purity reagent gas for maximum sensitivity and good spectral quality. Impurities in the reagent gas may limit the number of sample ions that can be formed, which reduces spectral sensitivity. In addition, impurities may react with sample ions, creating confusing mass spectral data.

The amount of reagent gas consumed during CI operation is very low, typically 1 to 2 mL/minute. Use a K-size gas cylinder of the selected reagent gas.

The recommended gases, methane, isobutane, and ammonia must have a purity of 99.99% or better and use a gas cylinder with a two-stage pressure regulator that has a stainless steel diaphragm and maximum inlet pressure of 15 psi (1 bar). Ammonia must be anhydrous grade.

NOTE: For assistance in selecting and using other reagent gases, please contact your Varian Customer Support Representative.

The CI reagent gas must have less than 1 ppm of water. Water in the CI reagent gas may interfere with CI operation.

Use copper or stainless steel gas lines for methane or isobutane. Use stainless steel lines for ammonia. All gas lines must be free of oil (and other contaminants) and preferably flame dried. If possible, use the pre-cleaned copper tubing from the GC Start-Up Kit.



WARNING:
CHEMICAL HAZARD

DO NOT flame dry the reagent gas lines with CI reagent gas present.

Setting Up the CI Reagent Gas Supply

The following procedure describes how to set up the CI reagent gas supply.



WARNING:
CHEMICAL HAZARD

CI reagent gases may be hazardous. Use proper protection when installing the reagent gas.

1. Open **System Control** and click **Manual Control**.
2. Make sure that the electron multiplier, filament, and RF voltage are off. The Multiplier, Filament, and RF text should be red or black.

NOTE: Two solenoid-operated valves control the flow of CI reagent gas into the manifold. The valves are opened and closed by clicking the CI button in Instrument Control. A needle valve controls the amount of reagent gas flowing into the manifold. Adjust the needle valve, behind MS door, manually using the knob labeled CI GAS. Turn the knob clockwise to increase the flow of reagent gas. See the Functional Block Diagram of the Vacuum System on page 12.

3. Verify that the CI gas solenoid valves are closed. When these valves are closed, the CI Gas icon to the left of the ion trap symbol is not green. (If the CI icon is green, click on the icon so that it turns to red or black.)

4. Install a two-stage pressure regulator on the reagent gas cylinder or lecture bottle. Tighten the connection securely.

NOTE: A two-stage pressure regulator typically consists of the following components: Secondary valve, Pressure adjustment valve, Supply pressure gauge, and Delivery pressure gauge

5. Use the main valve to turn the gas on or off. The secondary valve on the pressure regulator is the coarse control of the flow of gas from the gas cylinder up to the pressure adjustment valve. The supply pressure gauge monitors the gas pressure in the bottle. The pressure adjustment sets the head pressure of the gas delivered to the MS.
6. Connect one end of the 1/8 in. OD gas supply line to the pressure regulator.
7. On the back of the MS, loosen the two screws that hold the plug in the CI Shutoff Manifold 2 to 3 turns.
8. Remove the plug by pulling straight out and twisting.

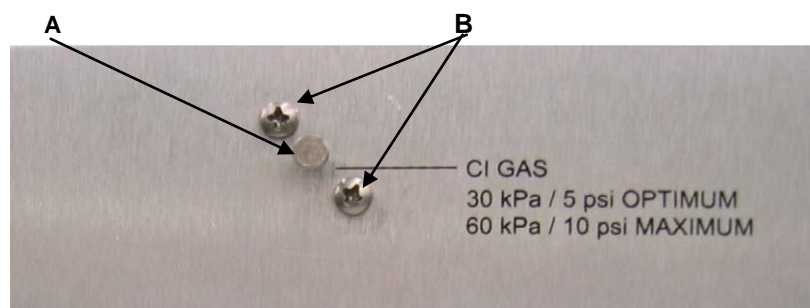

A	Plug	B	Screws
---	------	---	--------

9. Use 1/8 in. OD tubing for the supply line between the gas cylinder and the CI shutoff manifold. No ferrule is required on the MS end of this tube. The seal is made with an elastomer O-ring. Inspect the end of the tubing and ensure that the surface finish is smooth. If there are scratches, cut off the damaged part or use 200-600 grit abrasive paper to refinish the sealing end of the tube.
10. Carefully insert the tube into the CI shutoff manifold hole (where the plug came out of) until it is firmly seated. Be careful not to scratch the tube.
11. Tighten the two screws.
12. Ensure that the secondary valve on the regulator on the gas cylinder is closed.
13. Open the main control valve on the lecture bottle. Next, open the secondary valve and adjust the pressure adjustment valve to approximately 5 psi so that reagent gas flows at a moderate rate through the gas line.
14. Open the MS door. Verify that the CI GAS needle valve is turned fully counterclockwise.

15. Flush the gas line of air and water vapor as follows:
 - a. Turn the adjustment valve clockwise to reduce the pressure.
 - b. Open the CI gas solenoid valves by clicking on the CI icon in the Control and Status field of the Manual Control tab dialog in System Control. When the valves are opened, the CI button is green.
 - c. Evacuate the CI reagent supply line for about 30 minutes.

Checking the Reagent Gas Plumbing for Leaks

The troubleshooting section has procedures for checking for air leaks in the connections of the reagent gas line and for detecting water vapor in the gas line.

The following are modifications to the procedures that may be needed.

If there is a large air leak

1. Check the tightness of the CI GAS fitting on the rear of the instrument and the fitting on the pressure regulator.
2. Recheck the air/water spectrum.

If excess water vapor is indicated by a high 19/18 ratio, there may be water in the gas line or an atmospheric air leak in the reagent gas plumbing.

To check for water:

1. Shut off the flow of reagent gas into the manifold by closing the CI solenoid valves. If necessary, click on the CI icon in the Control and Status field of the Manual Control tab dialog in System Control. When the valves are closed, the CI button is black or red—not green.
2. Recheck the air/water spectrum. If the peak at mass 19 (for water) decreases, then water is present in the gas line. In this case, go to step 3. If the peak at mass 19 does not decrease significantly, then little water is present in the gas line. In this case, there is an air leak. Fix the leak as described in the Troubleshooting Section. Check for leaks around:
 - The CI GAS port on the rear of the MS.
 - The fitting connecting the reagent gas line to the pressure regulator.

To flush excess water from the gas line, do the following:

1. Ensure that the electron multiplier, filament, and RF voltage are off.
2. Open the main valve on the lecture bottle. (The secondary valve on the pressure regulator should be open.)
3. Turn the CI needle valve fully counterclockwise.
4. Open the CI gas solenoid valves and allow the system to pump down for about 1 hour.
5. Close the main valve on the gas cylinder but keep the CI GAS solenoid valves open. Allow the system to pump down for about 15 minutes.
6. Recheck the air/water spectrum. If excess water is not present, continue to the next procedure, Setting CI Reagent Flow.

Setting CI Reagent Flow

After leaks are fixed, set the delivery pressure of the CI reagent gas as follows:

1. Ensure that the CI gas solenoid valves are closed. If necessary, click the CI icon in the Control and Status field of the Manual Control tab dialog in System Control. When the valves are closed, the CI button is black or red—not green.
2. Open the main valve on the lecture bottle.
3. Adjust the pressure valve on the regulator, to set the head pressure to about 5 psi (34 kPa).

The system is ready to operate in the CI mode.

Default Parameters for Gaseous CI Reagents

Reagent Gas	Methane	Isobutane	Ammonia
CI Storage Level (m/z)	13	19	13
Ejection Amplitude (v)	9	15	9
Background Mass (m/z)	45	65	45
Target TIC	5000	5000	5000
Maximum Ionization Time (μ sec)	2000	2000	2000
Maximum Reaction Time (μ sec)	60	60	60
Prescan Ion Time (μ sec)	100	100	100

If you have the Liquid CI Inlet or the Multiple CI Module, use the following:

Default Parameters for Liquid CI Reagents

Reagent Liquid	Acetonitrile	d3-Acetonitrile	Methanol
CI Storage Level (m/z)	19	19	19
Ejection Amplitude (v)	15	15	15
Background Mass (m/z)	65	65	55
Target TIC	5000	5000	5000
Maximum Ionization Time (μ sec)	2000	2000	2000
Maximum Reaction Time (μ sec)	40	20*	40
Prescan Ion Time (μ sec)	100	100	100

* Use short reaction times for deuterated reagents. Longer reaction times allow more H/D exchange with background water and the resulting spectrum will show more $[M+H]^+$ and less $[M+D]^+$.

Ion Intensities for Standard CI Reagents

The CI Adjust function has recommendations of an acceptable level of CI reagent ions. The general principles are as follows:

Methane	Adjust the reagent gas pressure so that the peak heights at m/z 17 (CH_5^+) and 29 (C_2H_5^+) are about equal. The ratio of the ions at m/z 17 to m/z 16 should be about 10:1. The ion at m/z 41 (C_3H_5^+) should be visible.
Isobutane	Adjust the reagent gas pressure so that the peak heights at m/z 57 [$(\text{CH}_3)_3\text{C}^+$] and m/z 43 [$(\text{CH}_3)_2\text{CH}^+$] are about equal. There may also be an intense reagent ion at m/z 41 (C_3H_5^+).
Ammonia	Adjust the gas pressure so that the ratio of the peak heights at m/z 18 [$(\text{NH}_3)\text{H}^+$] to m/z 17 (NH_3^+) is about 10:1.
Acetonitrile	Adjust the reagent gas pressure so that the ion at m/z 42 [CH_3CNH^+] is about 10 times higher than at m/z 41. The valley between the 41/42 ions should reach a minimum at less than half the height of the m/z 41 ion. The m/z 54 ion [$\text{CH}_3\text{CHCNH}^+$] will be present at 10 - 15% the height of m/z 42. Too much acetonitrile in the trap can cause early filament failures.
d3-Acetonitrile	Adjust the reagent gas pressure so that the ion at m/z 46 [CD_3CND^+] is about 10 times higher than at m/z 44. The m/z 58 ion [$\text{CD}_3\text{CDCND}^+$] will be present at 10 - 15% the height of m/z 46.
Methanol	The ion at m/z 33 [$(\text{CH}_3\text{OH})\text{H}^+$] will dominate the spectrum. No ion is observed at m/z 32, but a small peak is observed at m/z 31 and m/z 47.

The reagent gas pressure in the ion trap will be approximately 1 to 2×10^{-5} Torr (about 1.3 to 2.6×10^{-3} Pa). The CI reagent molecules are about 1% of the gas pressure in the ion trap. Helium atoms from the column flow are present at 100 times this pressure.

Liquid CI Reagents

A liquid CI inlet assembly must be installed for the CI mode. Use the following instructions to install the liquid CI inlet assembly and, if necessary, to switch back to using gas CI reagents.

Installing the Liquid CI Inlet

1. Before beginning, shut down and vent the MS. If you are not disassembling the trap, you do not need to wait for the trap electrodes to cool down before installing the Liquid CI Inlet assembly.

2. Remove the top cover and then attach the Liquid CI Inlet assembly to the back of the MS using the following instructions. Refer to the following drawings.
 - a. From the back of the MS, remove one of the two screws that hold the CI shut-off block. Replace it, loosely, with a long screw supplied with the kit, part number 1222200625.
 - b. Remove the other screw.
 - c. Gently pull the free end of the liquid CI restrictor tube, part number 393002401 from the L-bracket where it attaches to the back of the MS, while leaving the other end of the restrictor tube attached to the Liquid CI Inlet block.
 - d. Loosely attach the Liquid CI Inlet assembly to the back of the MS using the L-bracket with the screw that was removed.
 - e. Rotate the Liquid CI Inlet assembly out of the way to remove the remaining screw.
 - f. Rotate the Liquid CI Inlet assembly back into position and loosely attach the liquid CI inlet assembly with the remaining long screw, part number 1222200625.
 - g. Reinsert the liquid CI restrictor tube through the L-bracket into the back of the MS. The restrictor tube must be inserted far enough to engage the O-ring in the CI shutoff block.

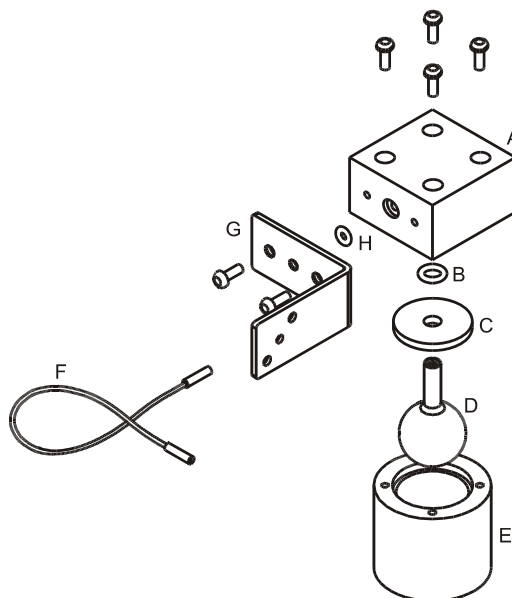

A	Inlet Block (393002301)	E	Reservoir Cover (393002601)
B	Viton O-ring (393010907)	F	Restrictor (393002401)
C	O-ring Retainer (393002501)	G	L-Bracket (393002701)
D	Reservoir Bulb, same as Cal Gas Chamber (392027000)	H	Viton O-Ring (393010904)

Liquid CI Inlet

3. Replace the long restrictor, part number 393059701, with 1/8" OD PEEK tubing, part number 393003701.
 - a. With the liquid CI inlet mounting screws still loose, pull out the long restrictor tube from the CI shutoff block.
 - b. Loosen the four screws on the top of the pneumatics manifold (at the front of the MS).
 - c. Pull out the long restrictor tube from the bottom of the pneumatics manifold. Carefully pull the tube out of the front of the MS. Save this long restrictor to use with pressurized gases such as methane.
 - d. Feed the PEEK tube, part number 393003701, into position, starting from the front of the MS (occupies roughly the same space as the long restrictor tube).
 - e. Gently install the PEEK tube end into the pneumatics manifold, being careful not to let the retaining plate scratch the tube.
 - f. Do not retighten the 4 screws on the pneumatics manifold yet.
 - g. Insert the other end of the PEEK tube into the CI shutoff block and tighten the 2 screws from the rear of the MS.
4. Replace the front restrictor.
 - a. Remove the existing short gas restrictor, part number 393059601, from the bottom of the pneumatics manifold.
 - b. Install the front liquid CI restrictor, part number 393059602, into the same location in the pneumatics manifold. Do not let the retaining plate scratch the restrictor tube ends.
 - c. Tighten the 4 screws on the pneumatics manifold.
5. Replace the top cover.

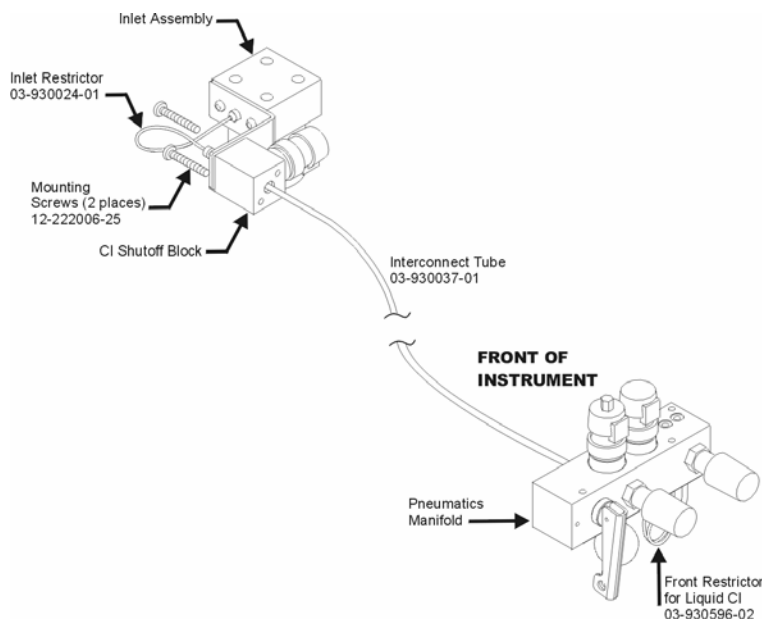

6. Restart the system.

Filling and Refilling the Liquid CI Reservoir Bulb

1. Be sure the CI valves are closed. Disengage the four screws that retain the liquid CI reservoir cover. They may remain in the block.
2. Remove the reservoir cover.
3. Gently pull the bulb down to remove it from the block. The O-ring and O-ring retainer may stay attached to the bulb.

NOTE: Solvent must not contact the O-rings.

4. Use the reservoir cover as a stand for filling; place the bulb into the reservoir cover.
5. Place the O-ring retainer over the bulb stem. Place the O-ring over the bulb stem.
6. Use a pipette or syringe to fill the bulb halfway with liquid CI reagent. This requires about 3 mL of reagent.
7. Pick up the reservoir cover with the bulb, retainer, and O-ring, and insert the bulb stem into the block.
8. Orient the cover so that the four screws can engage the cover. Tighten the four screws, being careful not to strip the threads in the plastic cover.

After installing the liquid CI and each time the reservoir bulb is refilled, always use care when first opening the CI valves. Do not turn on the filament or multiplier for about 2-3 minutes after opening the CI valves from the Instrument Page.

A convenient way to verify that air and water have been removed sufficiently is to check the ion gauge pressure with the CI valves open. Verify that the pressure has returned to less than 35×10^{-6} Torr before turning on the Filament and Multiplier.

Preserving Liquids in Reservoirs

When the reservoirs of the liquid CI reagents are not on the instrument, cap them with the provided yellow polypropylene caps



CAUTION

Never force the cap onto the glass reservoir stem—it can break.



**WARNING:
EYE HAZARD**

Use safety glasses and protective gloves, especially when attempting to remove a cap from a filled reservoir.

- Use a gentle, twisting/pushing motion to install the plastic cap onto the reservoir stem.
- Use a gentle twisting/pulling motion to remove the plastic cap from reservoir stem.



**WARNING:
CHEMICAL HAZARD**

Be careful not to spill any liquid, especially the few drops that may be in the neck of the bulb.

Setting Flows of Vapor from Liquid CI Reagents

1. Connect a liquid reagent reservoir containing the chosen liquid to the liquid reagent inlet block.
2. Open the CI needle valve 6–7 turns counterclockwise.
3. Open the CI solenoids by clicking on the CI button on the Manual Control page and allow the vapor flow from the reservoir to equilibrate. If, after several minutes, there is not enough CI gas entering the trap, increase the flow by turning the needle valve clockwise.
4. While observing the spectrum using Adjust CI Gas, turn the CI needle valve to increase or to decrease the amount of reagent entering the trap until the resolution between M and M+1 just starts to degrade. For best results when using acetonitrile, use a filament emission current of at least 20 μA and maintain at least 50% valley between m/z 41 and m/z 42. To examine the valley in a convenient way, click on the top of the m/z 41 peak and drag it to the top of the display using the cursor. See below for a properly adjusted acetonitrile spectrum and for a properly adjusted methanol spectrum.

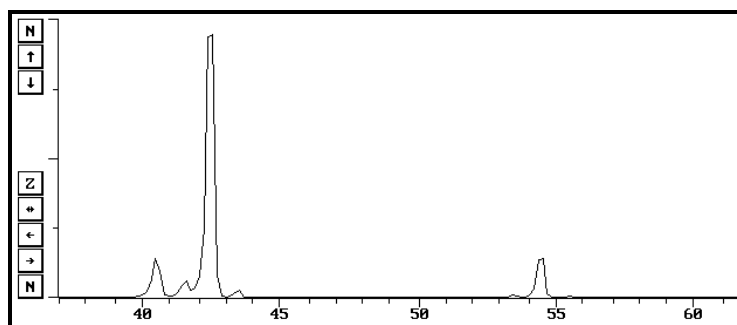

Properly Adjusted Acetonitrile Reagent Spectrum

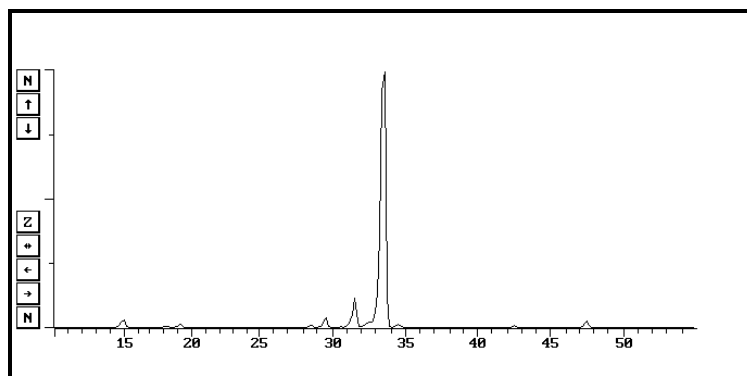

Properly Adjusted Methanol Reagent

Switching to Gaseous CI Reagent

To switch from the Liquid CI Inlet back to a pressurized CI gas (such as methane), the CI gas line may be reinstalled without removing the liquid CI inlet assembly.

1. Loosen the two screws that attach the liquid CI inlet L-bracket to the back of the instrument. Also, loosen the two screws that attach the L-bracket to the liquid CI inlet block.
2. Remove the liquid CI restrictor end that inserts into the back of the instrument; rotate the restrictor out of the way.
3. Install the long CI gas restrictor, part number 393059701, between the gas supply and the CI shutoff block, through the L-bracket.
4. Tighten all screws.
5. It is not necessary to replace the front liquid CI restrictor, part number 393059602, with the short gas restrictor, part number 393059601.
6. Reduce the gas pressure to 5 psi at the supply to return to normal gas CI operating conditions.

MS Maintenance

This section provides procedures for the routine MS maintenance tasks listed in Quick Reference.

Foreline Pump (210, 220-MS only)

Checking Foreline Pump Oil

If using a rotary vane pump, check the oil level and condition every 2 to 3 months. The pump should be switched off, but still warm.

1. Ensure the oil level is between the maximum and minimum levels on the sight glass. If the oil level falls below the minimum level, gradually add more oil, part number 8829953800, through the filler port until the oil level is centered between the maximum and minimum levels. A funnel may help.
2. Ensure the pump oil is clear and light amber in color.
 - If the oil becomes cloudy, purge it as described in “Purging Foreline Pump Oil” on page 42.
 - If the oil is thick and dark in color and has a burnt smell, change it as described in “Changing Foreline Pump Oil” on page 43.

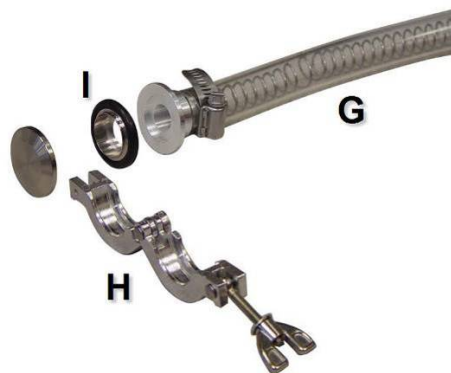
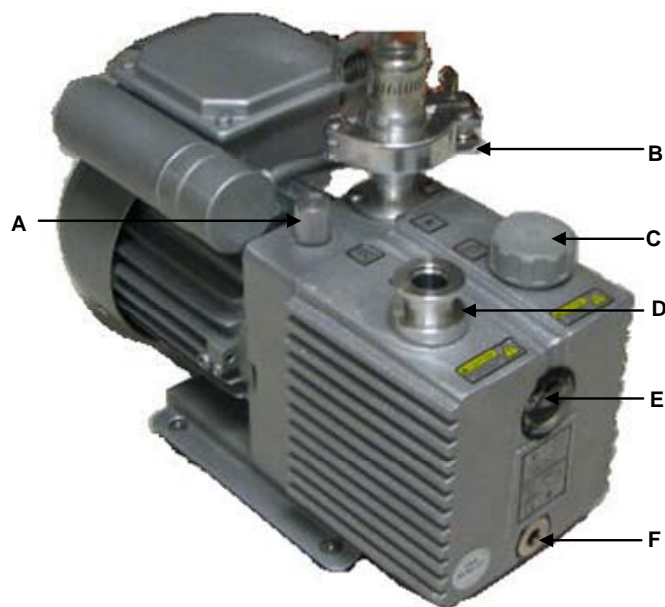

A	Gas Ballast Valve	F	Drain Plug
B	Air Inlet	G	Foreline Hose
C	Exhaust	H	Clamping Ring
D	Filler Plug	I	Seal
E	Oil Level Sight Glass		

DS-42 Foreline Pump

Purging Foreline Pump Oil

The condensation from sample vapors can accumulate in the foreline pump oil. This condensation can reduce pump efficiency and shorten the life of the oil. However, a weekly purge rejuvenates the oil.

Do not purge while the MS is acquiring data, when the filament is on, or when the electron multiplier is on.

To purge the foreline pump oil:

1. Place an exhaust vent over the open exhaust port.
2. With the foreline pump running, turn the gas ballast valve counterclockwise to the open position. The pump will become noisy and emit oil vapor.
3. After 10 minutes, turn the gas ballast valve back to the closed position.
4. Remove the exhaust vent.

Changing Foreline Pump Oil

To ensure peak performance and maximum pump lifetime, change the pump oil and the oil mist filter cartridge at least once a year or whenever the oil becomes thick, dark in color, and has a burnt smell. The oil change must be performed while the oil is warm.

To change the pump oil:

1. Turn off and vent the MS.
2. Disconnect the power cord of the pump from the rear of the MS.
3. Disconnect the vacuum hose from the foreline pump by removing the clamping ring.
4. Pull the hose free and then place the seal on a clean lint free surface for later use.
5. Carefully place the foreline pump on a raised surface. The surface should be high enough to allow a 0.5 liter (0.5 US qt) or larger container to be placed under the drain port when the pump is tilted forward. A container with an opening diameter of at least six inches will make this task easier.



CAUTION

The pump weighs 25 kg (55 lb.). To prevent personal injury, use proper moving and lifting techniques.

6. Place an oil pan beneath the drain port to catch any spillage.



WARNING: CHEMICAL HAZARD

Hazardous chemicals may be present. Avoid contact with skin. Use proper eye and skin protection.

7. Remove the plastic cover and the filler plug on top of the pump.
8. Put the container where it can catch the oil and then slowly remove the drain plug in the front of the pump.



WARNING

Toxic residues from MS samples build up in used pump oil. Dispose of all used pump oil in accordance with applicable regulations. Place a hazards warning label on the container, if necessary.

9. Tilt the pump forward and hold until oil flow ceases.
10. Return the pump to the horizontal and refit the plug.
11. Run the pump for approximately ten seconds with the intake port open. This will remove any residual oil from the pumping block.



CAUTION

Avoid breathing oil mist coming from the exhaust port during this operation.

12. Remove the plug, tilt the pump, and then drain the oil.
13. Return the pump to the horizontal position.
14. Wipe the oil residue from the drainage port and then refit the drain plug.
15. Fill the pump with fresh oil, part number 8829953800, through the filler port until the oil level reaches the maximum level in the sight glass. A funnel may be helpful.

Flushing Pump Oil

Flush the pump if the pump oil is particularly dirty. After draining the pump (previous steps 1-14):

1. Remove the inlet filter by removing the locking screw of the inlet port with a 4 mm Allen wrench; unscrewing the inlet port with a 30 mm open ended wrench; and pulling the filter up with a pair of tweezers or long nose pliers.
2. Clean the filter in warm soapy water. Rinse and blow-dry with air or nitrogen.
3. Refit the filter.
4. Screw the inlet port back into the pump housing and lock in place with the locking screw.
5. Pour 0.33-Liter / (0.35 US qt) of fresh pump oil in through the inlet port then run the pump.



CAUTION

Avoid breathing oil mist coming from the exhaust port during this operation.

6. Stop the pump, drain the flushing oil, and replace as described previously.

Changing the Oil Mist Cartridge (210, 220, and 225-MS)

The following explains how to change the cartridges for the DS-42 and the DS-102 Oil Mist Eliminators. When the cartridge is saturated, excessive mist or oil can spray out. The cartridge must then be replaced.

Replace the cartridge of the oil mist eliminator on the exhaust port of the pump when you change the oil.

The 225-MS has the same oil mist eliminator as the DS-42.

DS-42 Oil Mist Eliminator

To disassemble the oil mist eliminator:

1. Unscrew and remove Upper housing 1
2. Remove Spring 2
3. Remove Valve 3
4. Remove Cartridge 4
5. Clean the parts with a dry cloth.
6. Degrease with a water soap solution.
7. Rinse with clean water and dry.

To reassemble the oil mist eliminator:

1. Install a new cartridge.
2. Press gently to check that it is firmly seated.
3. Install Valve 3 so that the raised center fits inside the cartridge.
4. Center Spring 2 over Valve 3.
5. Cover entire assembly with Upper housing 1, ensuring that the O-ring gasket is flush against the housing.
6. Tighten Upper and Lower housings.

NOTE: After changing the cartridge several times, it may be necessary to replace the O-ring gasket.

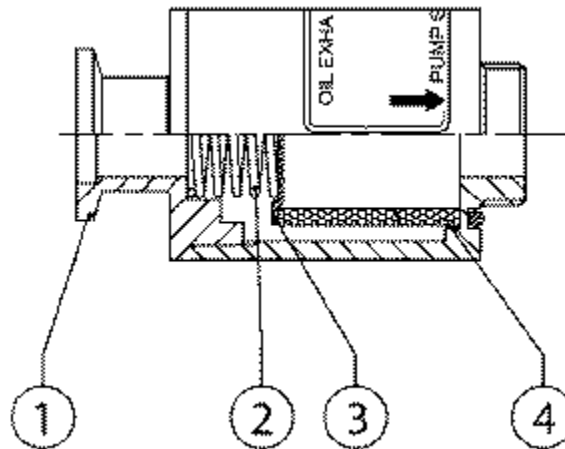

DS-102 Oil Mist Eliminator

To disassemble the oil mist eliminator:

1. Remove assembly screws A.
2. Remove Upper housing B
3. Remove Spring C
4. Remove Valve D
5. Remove Cartridge E
6. Remove O-ring F.
7. Clean the parts with a dry cloth.
8. Degrease with a water soap solution.
9. Rinse with clean water and dry.

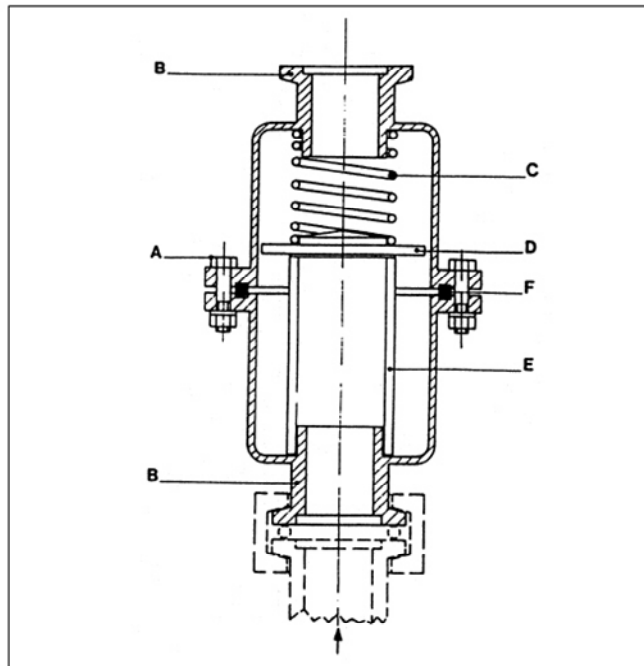

To reassemble the oil mist eliminator:

1. Install a new cartridge in Lower housing B.
2. Press gently to check that it is firmly seated.
3. Install Valve D with polished side toward cartridge.
4. Center Spring C over Valve D, and fit gasket, F in the groove.
5. Cover entire assembly with Upper housing B.
6. Tighten Upper and Lower housings B, using screws A.

NOTE: After changing the cartridge several times, it may be necessary to replace the gasket and the centering O-ring gasket.

Checking Cooling Fans



To prevent overheating, do not block the air intakes of cooling fans.

The cooling fans maintain an optimal temperature for the turbomolecular pump and the electronics modules. Without the cooling fans, the lifetime of the turbomolecular pump and temperature-sensitive electronic components would be shortened. To ensure proper operation of the cooling system, operate the MS with its covers in place. In addition, check the fans at least once each week.

The MS has two fans on its rear panel. To check fan operation, do the following:

1. Make sure that the MS MAIN switch and SERVICE switch are turned ON. (See “**Error! Reference source not found.**” on page **Error! Bookmark not defined.** for a photo showing the locations of the main and SERVICE switch.)
2. Place a large sheet of paper over one of the fan guards.
 - If the paper is sucked toward the fan guard, the fan is working.
 - If it is not, the fan is broken. Contact your Varian Customer Support Representative to arrange for a replacement.
3. Check the second fan in the same manner.

If the fans are excessively noisy, for example, if they whine or whir, a fan may be about to fail and it should be replaced.

To identify which fan is about to fail, do the following:

1. Remove the top cover from the MS.
 - If the noise continues, go to step 3.
 - If the noise stops, go to step 2.
2. Turn off the electronics compartment fan using the SERVICE switch, and replace the top cover. (See “**Error! Reference source not found.**” on page **Error! Bookmark not defined.** for a photo showing the location of the SERVICE switch.)
 - If the noise returns, it is coming from the turbomolecular pump cooling fan. Proceed to step 4.
 - If the noise does not return, remove the cover and proceed to step 3.
3. This step is specific to the MS model.
 - 210-MS or 220-MS only: Turn off the electronics compartment fan using the SERVICE switch. (See “**Error! Reference source not found.**” on page **Error! Bookmark not defined.** for a photo showing the location of the SERVICE switch.)
 - If the noise continues, it is from the turbomolecular pump-cooling fan. Contact a Varian Customer Support Representative to replace it.
 - If the noise stops, it is coming from the electronics compartment fan.
 - 225-MS only: Contact a Varian Customer Support Representative replace of the IPS module.

Replacing the Turbomolecular Pump (210-MS and 220-MS)

To disconnect the turbomolecular pump, do the following:

1. Turn off the MS.
2. Confirm that the main power switch is turned OFF, the vacuum system has been vented, and the power cord is unplugged.
3. Taking care not to break the GC column, slide the MS about 12 to 18 inches away from the GC.
4. Remove MS cover by grasping both sides and lifting up.
5. Disconnect the 1/8 in. pneumatics exhaust tube from the vacuum hose elbow.
6. Disconnect the vacuum hose elbow from the turbomolecular pump by removing the clamping ring and pulling the elbow away from the pump.
7. Pull the vacuum hose as far as you can toward the rear of the instrument.
8. Remove the turbomolecular exhaust-port seal and place it on a clean, lint-free surface for later use.
9. Unplug the turbomolecular cable from the turbomolecular pump by rotating the ring on the connector in the counterclockwise direction. Continue rotating until you can pull the connector free.

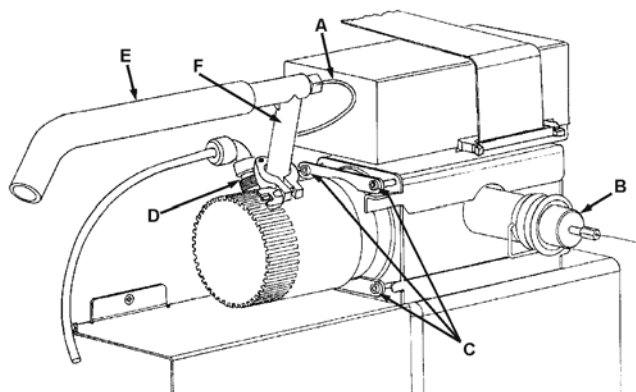

A	Pneumatics Exhaust Tube	D	Turbomolecular Cable
B	Transfer Line	E	Vacuum Hose
C	Clamping Screws (4 places)	F	Vacuum Hose Elbow

Turbomolecular Pump Connections

To unsecure the turbomolecular pump, do the following:

1. Loosen each of the four clamping screws about 2 turns with a 3/16 in. ball head hex driver.

NOTE: Do not completely unscrew the two inner clamping screws. (If you should unscrew them, put the screws back after you removed the turbomolecular pump from the MS.)

2. Remove the outside bottom clamping screw.
3. Remove the bottom clamp, while holding the turbomolecular pump in place.
4. Remove the outside top clamping screw (closest to the transfer line).
5. Remove the top clamp as you hold the turbomolecular pump in place.

To replace and to secure the turbomolecular pump, do the following:

1. Pull the turbomolecular pump to the back and lift it clear of the MS.
2. Remove the large seal from the turbomolecular inlet, and place it on the inlet of the new turbomolecular pump, part number 393076401. The orientation of the seal is not important.
 - Leave the red cap on the new turbomolecular exhaust port.
3. Carefully slide the new turbomolecular pump and seal into position on the end of the manifold.
 - Make sure the electrical connection (turbomolecular cable) is tilted towards the bulkhead, for example, toward the left as viewed from the rear of the MS.
 - Take care not to scratch the sealing surface on the manifold in front of the turbomolecular pump.
4. Insert the top clamp and loosely fasten it into place.
5. Insert the bottom clamp and loosely fasten it into place.
6. Tighten all four clamping screws until snug.

To reconnect the turbomolecular pump to other components, do the following:

1. Reconnect the turbomolecular cable. Rotate the retaining ring clockwise with downward pressure to lock the cable into position.
2. Remove the red cap on the turbomolecular exhaust port.
3. Place the seal on the turbomolecular pump exhaust port.
4. Reconnect the vacuum hose elbow and clamp.
5. Reconnect the pneumatics exhaust tube.

To finish installing the turbomolecular pump, do the following:

1. Make sure that the vent valve is closed.
2. Plug in the power cord.
3. Turn on the rear-panel main power switch.
4. Tighten the top and bottom clamp screws.
5. Monitor the turbomolecular pump speed using Diagnostics under Vacuum System Status.
6. Once the pump is running satisfactorily, replace the top cover and then slide the GC and MS back together.
7. Discard the old turbomolecular pump. Be sure to comply with all applicable health and safety regulations.

Replacing the Turbomolecular Pump (225-MS)

Contact a Varian Customer Support Representative to arrange for the replacement of the IPS module

Servicing the Ion Trap

Service the ion trap if it needs to be cleaned or to replace the filaments or the multiplier. The following flow chart illustrates the general sequence of ion trap maintenance operations. Each step is then described in detail.

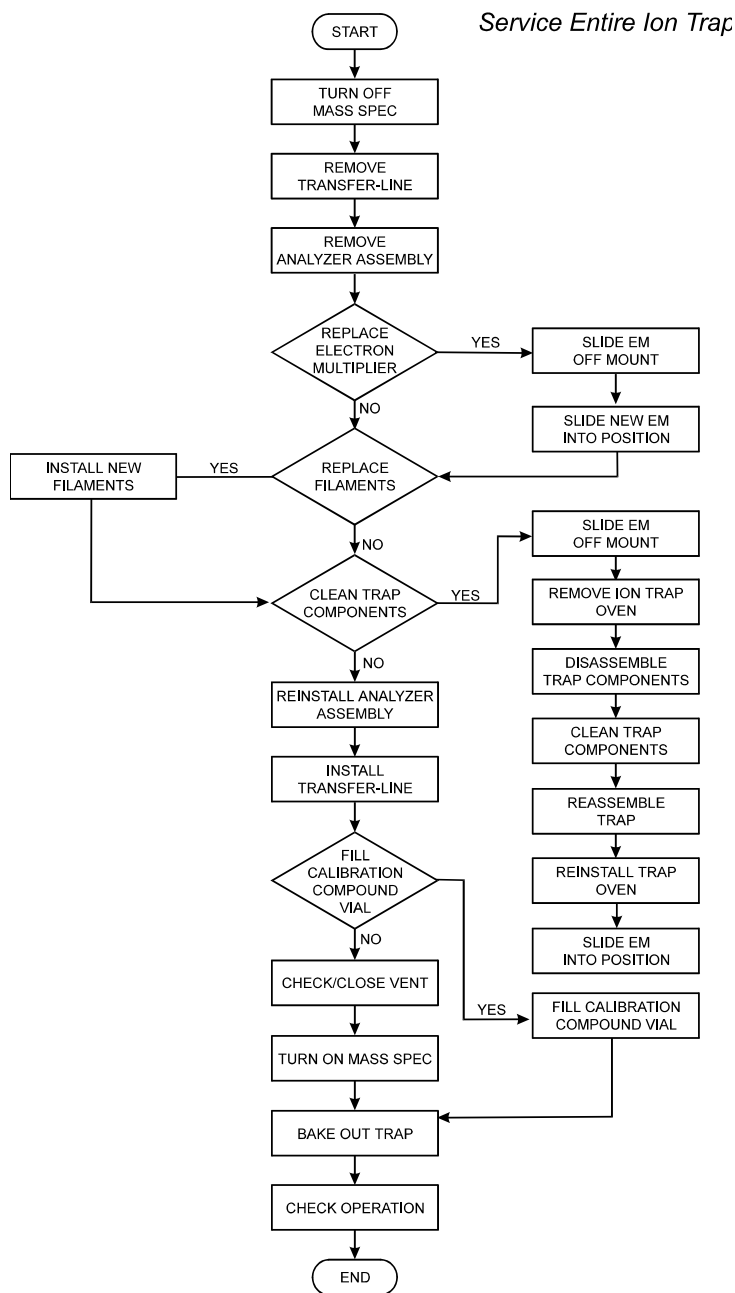

Turning Off the MS



**WARNING:
BURN HAZARD**

Allow heated zones to cool before disassembly.

To turn off the cooled MS, do the following:

1. Shut off the turbomolecular pump, foreline pump, and all electronics by turning off the main power switch on the back panel.
2. Disconnect the MS power cord.
3. Open the front panel door and lift the toggle vent valve for 1 second to slow the turbomolecular pump down.
4. After the pump stops spinning down, open the vent valve. Leave it open until the system is fully vented, for example, about 5-10 minutes.

Retracting the Transfer Line

NOTE: Fully vent the analyzer assembly before attempting to retract or remove the transfer line. Vacuum makes retraction of the transfer line difficult.

To retract the transfer line, do the following:

1. Hold the transfer line nose.
2. Simultaneously push and rotate the transfer line nose counterclockwise.
3. Pull the transfer line away from the analyzer.

Under most conditions, the transfer line needs only to be retracted in order to remove the analyzer. If it is necessary to remove the transfer line (for example, to inspect or change the O-ring), perform steps 4 and 5.

4. Remove the nose clip by gently pulling both sides away from the boot.
5. Pull the nose away from the analyzer until the entire assembly is free of the transfer-line shell.

Be careful if the column is connected to the transfer line.

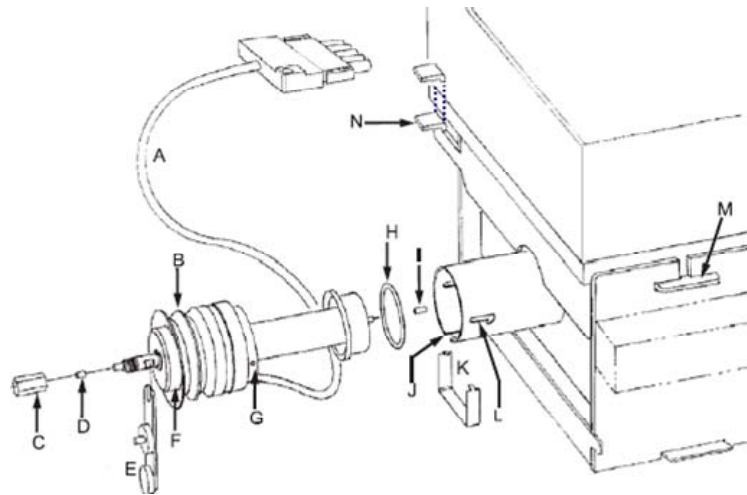

A	Heating Cable	H	O-ring
B	Boot	I	Transfer Line Tip
C	Nut	J	Heating Cable Slot
D	Ferrule	K	Nose Clip
E	Tool	L	Bayonet Mount
F	Nose	M	Analyzer Assembly Tongue
G	Nose Hole	N	Analyzer Assembly Lock-Down Tabs

Transfer Line Assembly

Removing the Analyzer Assembly



Retract transfer line before removing analyzer assembly.

NOTE: Be sure the transfer line is retracted. Otherwise, you cannot remove the analyzer assembly without damaging the analyzer. To prevent contamination, while handling the parts, wear latex or nitrile gloves.

To remove the analyzer assembly, do the following:

1. Remove the top cover of the MS by grasping both sides and lifting up.
2. Unplug the trap heater harness located near the top of the instrument.
3. On the side of the analyzer assembly (near the transfer line), push out the locking tabs on the power ribbon cable. This releases the cable.
4. Pull the ribbon cable out and move it away from the analyzer.
5. Push down and spread the two analyzer release tabs.

NOTE: Some MS systems have a transfer line removal flap that blocks the locking tabs. If such a flap is present, tip it out of the way during the procedure and return it to its original position once the analyzer is replaced.

6. Tilt the rear end up carefully to remove the analyzer.
7. Move the analyzer assembly toward the rear to free the front tab.
8. Place the analyzer upside down on a flat surface.

Replacing the Electron Multiplier

The electron multiplier should sit as close as possible to the ion trap. The electron multiplier grid should never be in contact with the trap.

To remove the electron multiplier, do the following:

1. Slide the electron multiplier back along its track until it clicks into place.
2. Continue sliding the electron multiplier, but with slightly less force, until the multiplier bracket is free of the track.
3. To protect the electron multiplier, place it with one of its sides facing down on a flat surface. Do not let the glass multiplier touch anything.

To install the new electron multiplier, proceed as follows:

1. Slide the electron multiplier forward along its track.
2. Push the multiplier bracket forward until it is as close as possible to the ion trap. The assembly should snap into place.
3. Make sure the high voltage and signal contacts are in good contact with the feed-through pins.

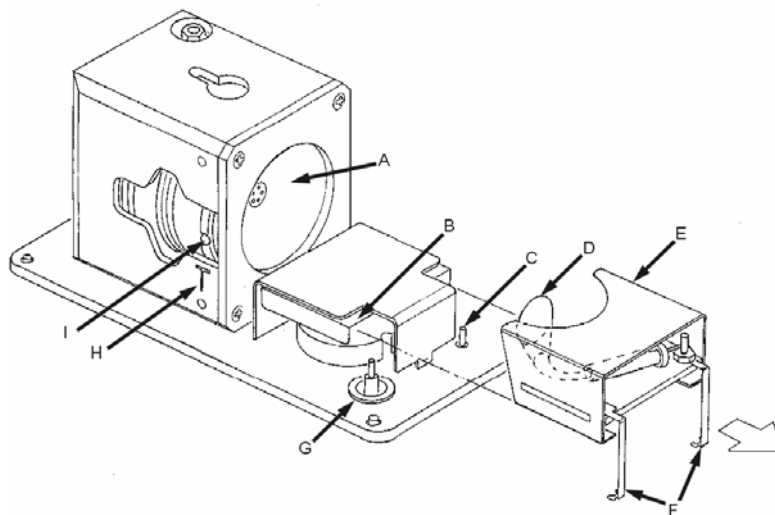

A	Exit-End Cap	F	Multiplier Contacts
B	Electron Multiplier Track	G	Multiplier High Voltage Pin
C	Multiplier Signal Pin	H	Transfer Line Alignment
D	EM Grid	I	Transfer Line Entrance Hole
E	Electron Multiplier Mount		

Electron Multiplier

Replacing the Filament(s)

To replace the filament(s), do the following:

1. Turn the trap so the filament assembly is facing you.
2. Disconnect the filament connectors from the flange feed-through pins by gently pulling each pin connector up until the wires are free from the pins.
3. Loosen the screw on the filament retainer with a Phillips screwdriver.
4. Slide the filament clip down off the ceramic filament disk.
5. Remove the filament assembly.

NOTE: Inspect the area around the filament entrance hole for carbon deposits. Carbon buildup in this area can lead to lower sensitivity and/or shorter filament lifetime. Area should be cleaned before replacing filament assembly.

6. Place the new filament assembly in the trap oven with the flat side down (towards the analyzer plate, G), and align the posts in the 1, 2, and C positions.
7. Slide the filament clip onto the filament disk and tighten the screw. Be sure that the clip is not touching any of the filament connectors.
8. Connect the filament connectors to the flange post connectors.

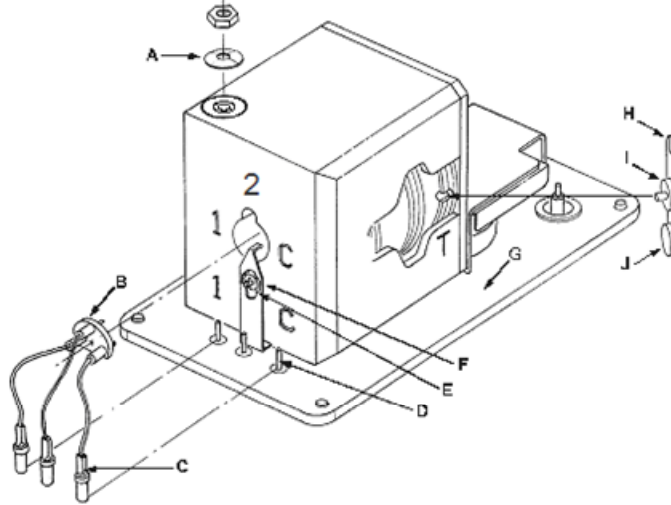

A	Belleville Washer	F	Filament Retainer
B	Ceramic Filament Assembly	G	Analyzer Flange
C	Filament Connectors	H	Transfer Line Alignment Tool
D	Post Connectors for Filament	I	Center Disk
E	Screw	J	Feeler Disk

Filament Assembly

Removing the Ion Trap Oven

NOTE: Wear gloves while removing the ion trap oven,

1. Remove the electron multiplier and place it on its side.
2. Disconnect the filament wires from the flange feed-through pins (labeled 1, 2, and C) by gently pulling each pin connector up until all wires are free of the flange.
3. Remove the nut using the 11/32 in. nut driver, which is supplied.
4. Gently lift the trap oven assembly off the heater post and thermo well.



CAUTION

Do not rotate the assembly more than 2 degrees. Otherwise, you may damage the contact springs.

5. Turn the analyzer assembly over to remove the Belleville washer.

Cleaning the Trap Components

The following procedures are used to clean the trap components:

1. Disassemble the trap components.
2. Clean the trap components.
3. Reassemble the trap.

Disassemble the Trap Components

1. Place the oven filament side down on its feet to protect the filament wires from damage.
2. Loosen the two screws with slotted holes by 3 to 4 turns. Do not remove the screws.
3. Completely remove the two screws in the non-slotted holes.
4. Slide the clamping plate off the trap oven.
5. Lift out the entire electrode stack, or remove each piece singly.
 - Be very careful not to damage the quartz spacers.
6. If you are only cleaning the electrodes, leave the gate parts in the oven. Otherwise, remove the gate, wavy spring washer, and gate conductor by turning the oven upside down.

NOTE: The Silica-Coated Spacers have a shiny, mirror like finish on the inside surface.

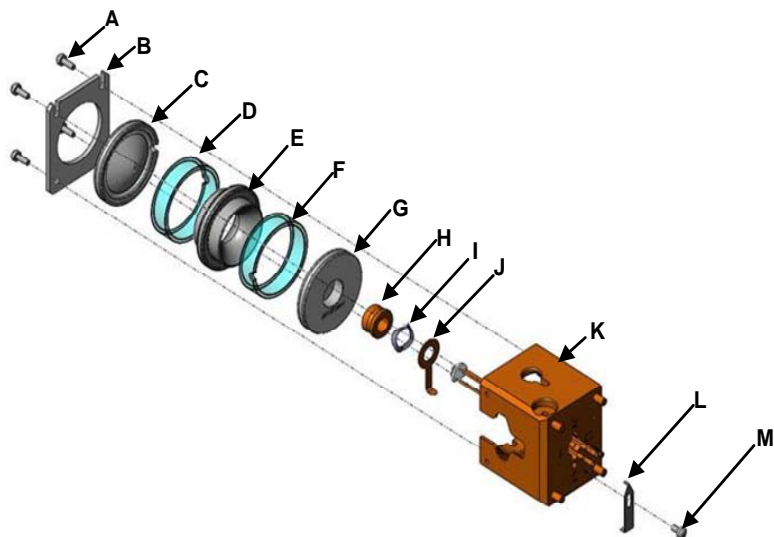

A	Screw, 6/32 in. , 4 places	H	Wave Washer
B	Clamping Plate	I	Gate Conductor
C	Exit-End Cap	J	Trap Oven, "T" is located this side.
D	Quartz or Silica-Coated Spacer, 2 pieces	K	Filament Assembly
E	RF Ring Electrode	L	Filament Clip
F	Filament-End Cap	M	Screw
G	Electron Gate		

Ion Trap Assembly

Cleaning the Trap Components

Use the following procedures to clean the ion trap parts:

- Clean the chrome-plated or silica-coated parts
- Clean the quartz spacers

NOTE: For silica-coated electrodes, do not use aluminum oxide.

Cleaning Chrome Plated Parts

To clean the filament-end cap, RF voltage ring electrode, and exit-end cap, proceed as follows:

1. Remove all contaminants from the stainless steel ion trap parts using a slurry of number 600 aluminum oxide in water (or glycerol) and a cotton-tipped applicator.
 - Use the wooden end of a cotton swab, cut at an angle, to clean the inside corners, for example, the holes in the end caps.

- Contaminants sometimes appear as dark or colored areas, but they may also be invisible. Clean each part thoroughly, even if there is no apparent contamination.
 - After you clean a part, hold it under running water and use a clean applicator to remove the last visible traces of aluminum oxide.
2. Immediately place the clean part in a beaker containing a solution of detergent and warm water.

NOTE: Do not let the slurry dry on the metal. Dried aluminum oxide is difficult to remove.

3. When you have finished cleaning all of the parts, place the beaker in an ultrasonic cleaner, and subject the beaker and its contents to ultrasound for about 1 minute.
4. Rinse each part with fresh water.
5. Using clean tools, place the parts in a beaker containing de-ionized water, and then subject the beaker and its contents to ultrasound for about 1 minute.
 - If the water is cloudy afterwards, replace the deionized water and repeat.
6. Rinse the parts with methanol.
7. Place the parts in a beaker of fresh methanol. Subject the beaker and its contents to ultrasound for about 1 minute.

NOTE: After the ion trap parts are clean, wear clean, lint-free gloves for succeeding procedures to prevent contamination. Do not wear vinyl gloves.

8. Remove the ion trap parts from the beaker, and place them on a clean, lint-free surface.
 - Allow the parts to dry in air.
9. Inspect each part to make sure that all spots and particles have been removed.
 - If you observe any contamination, clean the part again using the procedure described above.

NOTE: Clean any small parts, such as, the electron gate conductor, the gate, and wavy washer spring, by placing them along with the other parts in a beaker with methanol and subjecting them to ultrasound for 1 minute.

Check the oven trap near the filament entrance hole for carbon deposits. Carbon buildup may decrease sensitivity and shorter filament lifetime. Remove the carbon stains *only* with a cotton swab and methanol. After cleaning, check filament entrance hole for particles and fibers. The area must be cleaned before reassembly.

Cleaning Silica-Coated Electrodes

The silica top surface of the silica-coated Ion Trap Electrode is a very thin (only about 1 μm), but durable layer which is strongly bonded.



DO NOT use Aluminum Oxide or other abrasives because this will remove the silica layer on the trap!

DO NOT use harsh laboratory cleaners because this will remove the silica layer on the trap! Use only mild detergent (pH between 6 and 7.5).

For routine cleaning of the Silica-Coated electrodes, ultrasonicate the ion trap electrodes for 10 minutes in methylene chloride or methanol. Use separate beakers for each electrode to avoid scratching trap surfaces. Trap disassembly and reassembly is otherwise identical to the procedure in the Maintenance Section.

If heavy matrix (dirty) samples are routinely run on the instrument and the electrodes are visibly discolored where the column enters the trap at the multiplier end cap, use a toothbrush and liquid hand soap or dish detergent (pH between 6 and 7.5) to gently scrub the trap parts. Rinse the trap and then sonicate it in water and then twice in methylene chloride or methanol.

NOTE: The initial hydrocarbon background on the coated ion trap is higher than on the standard ion trap. To speed up the bakeout, you may want to bake out the ion trap overnight at 220 °C. In the bakeout mode, the manifold is set to 120 °C.

Cleaning the Quartz or Silica-Coated Spacers

NOTE: The Silica-Coated Spacers have a shiny, mirror like finish on the inside surface.

1. Wipe all surfaces of the quartz spacers with a clean, soft, lint-free cloth that has been dampened with reagent-grade acetone.
2. Subject the quartz spacers to ultrasound in acetone for 5 minutes.
3. Rinse each of the quartz spacers with de-ionized water.
4. Subject the quartz spacers to ultrasound in methanol for 5 minutes.
5. Dry the spacers in air or in an oven set to approximately 120 °C for 30 minutes.

Reassembling the Trap

To reassemble the trap assembly, do the following and refer to the Ion Trap Assembly figure:

NOTE: The orientation of the trap components is important. Make sure that all parts are free of particles, lint, and so on.

1. Replace the gate conductor, tab-down into position.
2. Replace the wavy washer on the gate conductor. The washer orientation is not important.
3. Replace the gate so that the flat, shiny surface faces the washer.
4. Replace the filament (single-hole) electrode in the oven.
5. Replace one of the quartz spacers so that the notch faces the filament (single-hole) electrode.
6. Replace the RF electrode, followed by a quartz spacer. The notch in the quartz spacer should face up towards the exit (seven-hole) electrode.

NOTE: Make sure that the notch in the quartz spacer and the notch in the exit-end cap are aligned.

7. Replace the exit (seven-hole) electrode so that the notch on this electrode faces the side of the trap labeled with the side-ways T.
8. Slide the clamping plate under the screws on the top of the trap oven assembly.
9. Visually check the transfer line hole, making sure that notches in the quartz spacer and exit-end cap electrode are aligned and centered in the trap oven.
10. Tighten the screws.

Reinstalling the Trap Oven Assembly

To reinstall the trap oven assembly, do the following:

1. Gently slide the trap assembly onto the heater post and thermo well, taking care not to bend the end cap contact springs.



Do not rotate the assembly more than 2 degrees or, you may damage the contact springs.

2. To set transfer line hole height to the analyzer flange, place the nub of the center disk into the hole created by the notches in the quartz spacer and the exit (seven-hole) electrode.
3. Rotate the alignment tool so that the feeler disk touches or almost touches the analyzer flange. Proper alignment is achieved when the feeler disk touches the analyzer flange and the alignment tool is perpendicular to the flange.
4. Replace the Belleville washer so that the crown side is facing upwards.

NOTE: When reinstalling the trap assembly, make sure that you orient the Belleville washer crown side up. Tighten the nut until the Belleville washer is flat, for example, until the nut bottoms out.

5. Replace and tighten the nut until it is snug.
6. Attach filament wires 1, 2, and C, to the flange feed-through pins.

Repositioning the Electron Multiplier

To install the electron multiplier, do the following:

1. Slide the electron multiplier forward along its track.
2. Push the multiplier bracket forward until it is as close as possible to the ion trap. The assembly should snap into place.
3. Make sure the high voltage and signal contacts are in good contact with the feed-through pins.

Reinstalling the Analyzer Assembly

To reinstall the analyzer assembly, do the following:

NOTE: Make sure that the manifold O-ring is clean and free of particles and fibers.

1. Make sure the transfer line is retracted or removed.
2. Align the analyzer with the release tabs toward the rear of the instrument.

NOTE: Take care not to scrape or bang the analyzer parts against the stainless steel manifold flange.

3. With a slight forward downward tilt; check that all cables and hoses are out of the way. Slowly insert the front tongue into the slot.
4. Lower the rear of the analyzer by spreading the release tabs and pushing down gently.

You should be able to install the analyzer assembly into the manifold without applying force.
5. Engage the release tabs and make sure that the release tabs are secure in their notches.
6. Connect the trap heater cable.
7. Connect the power ribbon cable and lock it into place. Ensure that the cable is firmly connected and that the locking tabs are fully engaged.

Installing the Transfer Line

If the transfer line was removed, reinstall the transfer line as follows. If the transfer line has only been retracted, go to steps 6 and 7 only.

1. Make sure the O-ring is free of lint, particles, and so on.
2. Insert the assembly into the transfer-line shell.
3. Orient the assembly so that the heating cable fits inside the shell slot.
4. Rotate the nose so that the nose holes line up with the small slots in the shell. These holes are found at the 4:00 and 10:00 positions.
5. Install the nose clip.

6. Push the nose in, rotating it clockwise to lock it in place.
7. Connect the transfer line heater cable.

Closing the Vent

To close the vent, or to check that it is closed, the vent valve lever should be facing down.

Turning On the MS

To turn on the MS, do the following:

1. Make sure that the power switch on the back of the MS is OFF.
2. Check that all heater cables are plugged in.
3. Plug in MS power cable.
4. Turn ON the MS power switch.
5. Open **System Control** on the computer.
 - The most recently set instrument parameters are loaded into the MS.
 - The software stays on the shut down page until the MS fully restarts.
6. Briefly press the analyzer assembly to ensure a good vacuum seal.
7. Replace the MS system cover.

Baking Out the Trap

To bake out the trap, do the following:

1. Enter the following bakeout conditions in the software:
 - Time: 2 to 6 hours
 - Trap Temperature: from 220 °C to 250 °C
 - Manifold temperature: 120 °C.

Checking the Ion Trap Operation

To check the ion trap operation, do the following:

1. After bake out is finished, re-establish the analysis temperature in the trap for at least 2 hours to achieve thermal equilibrium. The manifold temperature should be below 50 °C.
2. Run **Diagnostics**.
3. Run **Auto Tune** or manually tune the MS.

Filling the Calibration Compound Vial

The calibration compound is perfluorotributylamine (PFTBA; C₁₂F₂₇N), which is also known as fluorocarbon-43 (FC-43).

NOTE: There is no need to vent the vacuum system before you fill the cal gas vial with calibration compound, provided the cal gas needle valve is closed. To close the cal gas needle valve, turn it clockwise.

To fill the cal gas vial, do the following:

1. Locate the four screws on the top of the pneumatics manifold.
2. Loosen each of the four retaining screws about 3 turns with a Phillips screwdriver.
3. Pull the cal gas vial down gently with a slight twisting motion until it clears the pneumatics manifold.
4. Refill the vial using a Pasteur pipette until the vial is filled about 1/3 full with PFTBA compound, part number 392035300.
5. Remove any liquid that remains in the neck of the vial with a lint-free paper tissue.
6. While holding the vial vertically, carefully push the vial into the cal gas port on the manifold with a slight twisting motion.
7. After you have pushed the vial in as far as it will go, tighten the four retaining screws.
8. Open the cal gas needle valve 10 counterclockwise turns. Leave the needle valve open for at least 30 minutes to pump away any excess cal gas and water vapor.
9. Open **System Control** on the computer, and then click **Manual Control** button.
10. Under the **Adjustments** tab, select **Adjust Cal Gas**.
11. Adjust the cal gas pressure according to the instructions on the screen.

Moving the MS

210-MS or 220-MS

To move the 210-MS or the 220-MS, do the following:

1. Shut down the GC and MS.
2. Turn off the GC and computer. Then unplug the GC, MS, and all other power cords.
3. Open the vent valve lever on the front of the MS for ten minutes.
4. Watch the capillary column inside the GC as you gently slide the MS away from the GC. Do not bend or kink the capillary column.
5. Use the alignment tool to prevent the transfer line from turning while you loosen the brass capillary nut connecting the column to the transfer line.

6. Cap the transfer line with a capillary nut and no-hole ferrule.
7. Place the capillary column and nut inside the GC oven to protect them from damage.
8. Turn off the carrier gas, and then disconnect the helium gas line connected to the GC filter.
9. Cap the filters with Swagelok plugs or caps.
10. Move the MS to its new location. Be sure the new location satisfies the power and environmental requirements described in the Pre-installation Instructions.

225-MS

To move the 225-MS, contact your Varian Service Representative.

Troubleshooting

Isolating the Problem

Check the system in the following order:

1. Data System
2. GC
3. MS

Checking the Data System

Refer to the software release notes for relevant software troubleshooting procedures.

Checking the GC

Run a test sample to check operational and performance factors, including the carrier gas supply, chromatographic characteristics, and sample-related problems.

The test sample that is most frequently run is the COLTEST mixture. This multicomponent mixture is suited to troubleshooting injector and column problems. Please see “Running the COLTEST Sample on page 83. See the GC manuals for information about fixing GC problems. Ensure that you are thoroughly familiar with all safety issues before you repair any electronics component.

Checking the MS

If your data system and GC are operating normally, the problem could be caused by the MS or by the communication channel between it and the data system. Typical problems with the ion trap include lack of response (no spectra), low response, poor resolution, and mass miss-assignment.

Two procedures isolate problems associated with the MS.

- Auto Tune provides information about system performance.
- The diagnostics program tests the hardware and helps to isolate simple ion trap problems, for example, air leaks, burned-out filaments, and high contamination levels

NOTE: If diagnostics fail, after the problem is corrected, click the **Reset** button before doing further testing.

Sometimes, you may need to separate the GC and MS to isolate an ion trap problem. In these cases, remove the column from the injector, and plug its end with a septum. This minimizes the input of air. Maintain the column and transfer line at ambient temperature to prevent degradation of the stationary phase. You do not need to vent the MS vacuum system to complete this procedure.

To isolate the MS further, remove the column from the ion trap by shutting down the system and capping the transfer line with a no-hole ferrule.

Resolving Problems with Spectra

The following describes common problems.

No Spectrum

NOTE: Bake out the MS for at least 2 hours before doing troubleshooting.

If a spectrum fails to appear when you click the ion trap icon in the Instrument Control Page, regardless of mass range,

1. Run Diagnostics to detect hardware problems.

If you have done this, resolved any hardware problems, and the missing-spectrum problem persists, continue with the following procedures. These procedures apply if the air/water or the cal gas peaks are missing.

2. Investigate the following:
 - The method segment is a FIL/MUL Delay and ionization is EI (AUTO or FIXED) mode. During FIL/MUL Delay the trap icon is red.
 - The filament is open.
 - The turbomolecular pump has stopped.
 - An RF adjustment is required.
 - The instrument parameters are inappropriate.
 - The trap has been incorrectly assembled.
 - There is a problem with the electronics.
 - The system has not finished baking out.

Checking for an Open Filament

Diagnostics determines if one or both filaments are open.

1. If one filament is open:
 - a. Open **System Control**, and click **Set Points**.
 - b. In the **Filament Selection**, select the other filament.
2. If both filaments are open:
 - a. Shut down the instrument.
 - b. Check the filament continuity and wire connections after removing the ion trap assembly from the manifold.
 - c. Replace the filaments, if necessary.

Checking the Turbomolecular Pump

The Diagnostics Vacuum test determines if the Turbomolecular pump speed reading is at least $100 \pm 2\%$.

Make sure the pump speed reading is at least $100 \pm 2\%$. If it is not, inspect cooling fans for proper operation.

Checking the RF Adjustment

To check if an RF adjustment is needed (particularly after you have changed the ion trap temperature), do the following:

1. Open **System Control**, and then click the **Manual Control** button.
2. Click, the **Adjustments** tab, and then click **Adjust RF Tuning**.
3. Adjust the RF ramp by turning the RF tuning screw.
4. Adjust the RF ramp until the highest value is minimized.
5. Click **Save Results**.

Checking the Method Parameters

To check the method parameters, do the following:

1. Open **System Control**, and then click the **Auto Tune**.
2. Select **Electron Multiplier Tune**, and then click **Start Auto Tune**.
3. Select **Air/Water Check**, and then click **Start Auto Tune**.
 - If air and/or water levels are out of range, go to the Air/Water leaks section.
 - If a spectrum is present, enter Method Editor and check if
 - You specified the EI ionization mode.
 - Make sure that the ionization storage level permits storage in the trap of the ions selected in the scan range.

4. If you are unsure of appropriate levels, then reset the parameters by clicking the **Defaults** button in each section.
 - a. Save your method file as Default.
 - b. Activate Default file, turn on trap and Cal gas. Check for cal gas spectrum.
5. If the spectrum returns, note which parameter(s) were causing the problem. If no spectrum is present, and the trap was recently disassembled, check the trap.

Checking the Trap Assembly

To check the installation of the oven components, do the following:

Look the **Axial Modulation** readback in the **Waveform System** box.

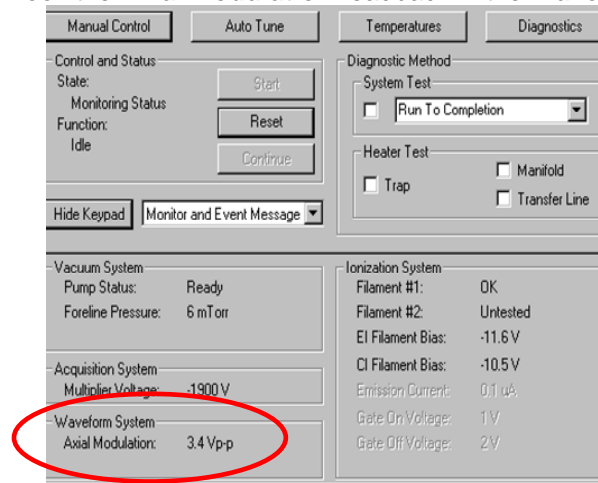

1. If the axial modulation readback is near zero, the trap oven may be scratched and shorting out one of the end caps. Shut down the system, remove the trap oven, and use an ohm meter to check for continuity between the electrodes and ground. Use the screws holding the clamping plate as ground. If this test is done without removing the trap from the electronics assembly, there will be continuity to ground.
2. To check if there is a problem with the electron multiplier, do the following:
 - a. Under Monitor States, select Multiplier.
 - b. Under **Acquisition System**, check that the electron multiplier voltage is the same or close to the value displayed in the **SetPoints** tab in the **Auto Tune** section.

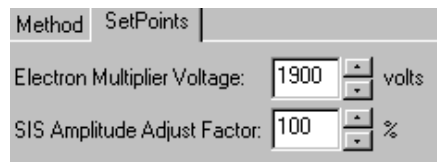

- c. If the electron multiplier voltage in the Diagnostics is only a few volts, the multiplier is shorted to ground. Shut down the system, and replace the electron multiplier or call a Varian Customer Support Representative.

Checking the Electronics

To check if there is an electronics problem, do the following:

1. From **Manual Control**, click **Diagnostics**.
2. Click **Run Tests to Completion** to isolate the cause of the problem. Note which of the tests fail.

NOTE: If, after performing these tests, the cause of the problem cannot be found contact your Varian Customer Support Representative.

Loss of High Mass Peaks

High mass peaks may be lost because of the following:

- RF ramp needs adjustment.
- Too many low mass ions (for example, air or water leak).
- Improper Ionization storage levels (for example, settings are too low).
- High Trap temperatures may cause loss of high mass cal gas peaks.

NOTE: Bake out the MS for at least 2 hours before doing troubleshooting.

If the problem persists, do the following:

1. Check for an air leak in **Auto Tune** section.
2. Check the RF ramp Adjustment.
3. Reduce trap temperature to 150 °C.
4. Enter **Method Builder** and then check that the method contains EI AGC (Automatic Gain Control) ionization mode, and Default values for other parameters.

NOTE: If, after performing these tests, you are cannot isolate the cause of the problem, contact your Varian Customer Support Representative.

Missing Part of the Spectrum

If you do not observe high or low mass ions in System Control, but the ions in the mid-range of the spectrum appear normal, investigate the following:

- An RF adjustment may be required, particularly if you have just changed the ion trap temperature.
- The ionization RF level may be incompatible with the scan range.
- The trap temperature may be too high to allow you to observe all of the cal gas ions. Reduce trap oven temperature to 150 °C, and wait 2 hours for thermal equilibration.

Checking the RF Adjustment

To check if an RF ramp adjustment is needed, do the following:

1. Open **System Control** and then click **Manual Control** button.
2. Click the **Adjustments** tab and then click on **Adjust RF Tuning**.
3. Adjust the RF ramp by turning the RF tuning screw on the front panel. Adjust to minimize the highest reading.

Checking the RF Storage Level

To check if the RF storage level is incompatible with the scan range, do the following:

1. Open the **Method Builder**.
2. Select **EI-AGC** segment, and click on **Ionization Mode**. Note Ionization Storage Level. Confirm values are appropriate for mass range.

Checking the Trap Temperature

If the trap temperature is too high to permit observation of all cal gas ions, do the following:

If the trap temperature is too high, the height of the mass 614 peak may be reduced, and the mass 502 peak may disappear entirely (above 200 °C). Reduce trap oven temperature to 150 °C and wait 2 hours for thermal equilibration.

NOTE: If, after performing these tests, you are still unable to isolate the cause of the problem, contact your Varian Customer Support Representative.

Poor Resolution with Acceptable Air and Water Levels

If the peaks are broader than expected, investigate the following:

- There are too many ions in the trap (for example, contamination, or high column bleed).
- The axial modulation value is too high or too low.
- Axial modulation is not functioning properly.

NOTE: Bake out the MS for at least 2 hours before doing troubleshooting.

Checking the Ion Content of the Trap

With the trap turned on, note the TIC (total ion current) value. If the TIC value exceeds 20,000 counts in full-scan mode, or a few thousand counts in MS/MS, reduce the number of stored ions.

To reduce the number of ions in the trap, do one or more of the following:

1. Make sure that the electron multiplier is set for a gain of 10^5 . In the **Method Builder**, check that the Multiplier Offset is equal to 0.
2. Reduce the trap filament current and/or ion time settings (AGC OFF).
3. Reduce the AGC target value to 10,000 (AGC ON).

Checking the Axial Modulation Setting

To check the axial modulation setting, do the following:

1. Click **SetPoints** from **Manual Control**. Make sure the axial modulation is set between 2.5 and 5 volts. If you adjust the axial modulation, check several cal gas ions for resolution (e.g., $m/z = 131$ and 414).
2. Check if axial modulation is working properly, by do the following:
3. Open **System Control**; turn on trap and cal gas. Click near m/z 131, to expand the mass range ± 5 about m/z 131.
4. Click **SetPoints** and then change the **Axial Modulation** by several volts. Click **Apply**. Confirm the shift of mass 131.
5. Return axial modulation to initial value.
6. Click the **Diagnostics** button from **System Control** and then select **Run Tests to Completion**. Confirm the axial modulation is working properly.
7. Make sure that the axial modulation readback is within 20% of the set point. If the axial modulation readback is out of this range, the cause may be the improper installation of the trap oven causing a shorted end cap.
8. If the oven is properly assembled and axial modulation is out of range, contact your Varian Customer Support Representative.

High Baseline at High Masses

If the baseline on the instrument page increases sharply between masses 400 and 650, investigate if there are particles on the electrode surface.

To check for are particles on the trap electrode surfaces, do the following:

1. Develop a method for EI/AGC ON for mass range 400 to 650. Open **System Control** and activate this method.
2. Turn on RF and the electron multiplier (filament is OFF).
3. Examine the spectrum, and notice whether the baseline increases exponentially at high masses.

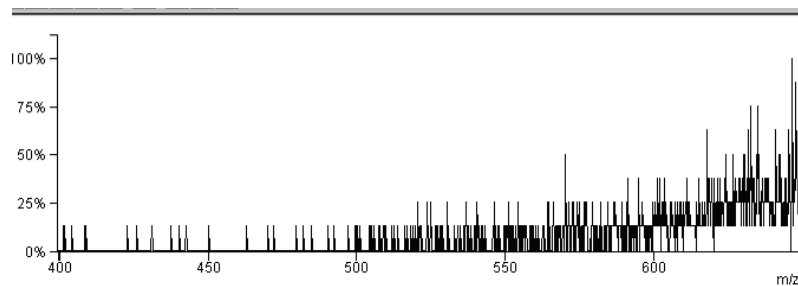

If the baseline ramps up, shut down the MS and then carefully clean the electrode surfaces with a lint-free cloth.

Trap Calibration Fails after Calibration Ions are Identified

If the trap function calibration fails after the calibration ions were correctly identified, check the following:

- The electron multiplier voltage is too low.
- The cal gas pressure is too low.

Checking the Electron Multiplier Voltage

1. Open **System Control**.
2. Select **Auto Tune** and then click on **Electron Multiplier Tune**.
3. Click **Start Auto Tune**.

Checking the Cal Gas Pressure

1. Open System Control.
2. Select **Manual Control** and then click on the **Adjustments** tab.
3. Click **Adjust Cal Gas** and then set the cal gas pressure to a value at the mid to high end of the scale.

Checking for Leaks

A major challenge in mass spectrometry is keeping the system as leak tight as possible. Air leaks may result in reduced sensitivity, tuning problems, and decreased resolution. They may reduce the lifetimes of the capillary column, filaments, and the electron multiplier. Check the system every day for air and water leaks before running samples.

Pay attention to examples with air and water backgrounds in the spectra. Familiarity with these examples will help to troubleshoot the system quickly.

Setting Up for Leak Checking

1. Verify that the carrier gas pressure on the gauge in the front panel of the GC is set correctly. With a 30 m x 0.25 mm, DB-5 fused silica capillary column, the carrier gas pressure should be about 10-12 psi (83 kPa).
2. Set the trap temperatures:
 - Trap heater temperature to 150 °C.
 - Transfer line temperature to 270 °C.
 - Manifold temperature to 35 °C.
3. Set the column-oven and injector temperatures to 100 °C.



Often, major air leaks are accompanied by a hissing sound. These leaks may be due to extremely loose fittings, improperly seated O-rings, or open valves. If you suspect a major leak, do not turn on the electron multiplier, RF voltage, or filament. Using the Diagnostics section, confirm that the turbomolecular pump is operating at 100% speed. If it is not, there is a major air leak.

4. Open **System Control** and then click **Auto Tune** button.
5. Select **Air/Water Check**.
6. Click **Start Auto Tune**.
7. Compare your air/water spectra to the following:

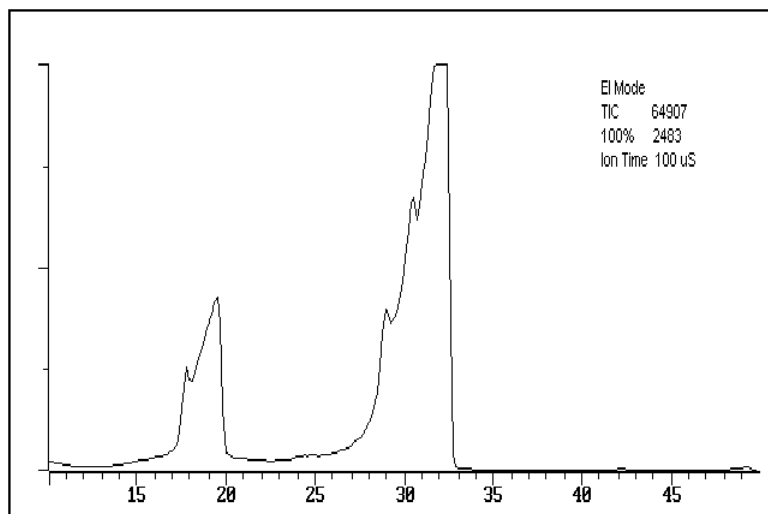

Air/Water spectrum from an instrument with a gross air leak

- If the peaks at masses 32 (O_2^+), 28 (N_2^+), and 18 (H_2O^+) are severely broadened or undifferentiated, the system has a large air leak. Immediately turn off Air/Water Check.

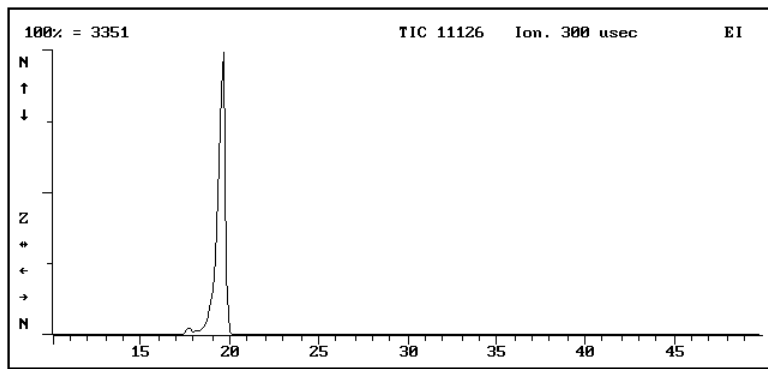
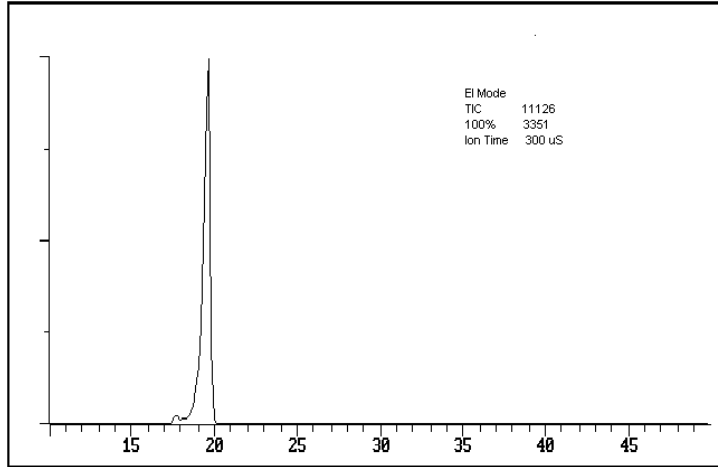

Air/Water Spectrum from a System with a Very High Water Vapor Background

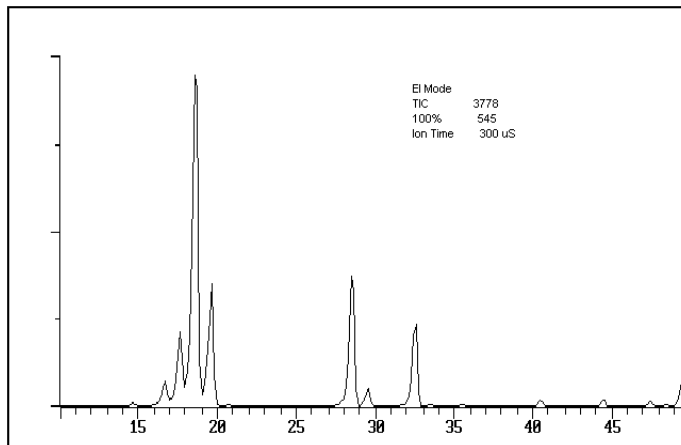

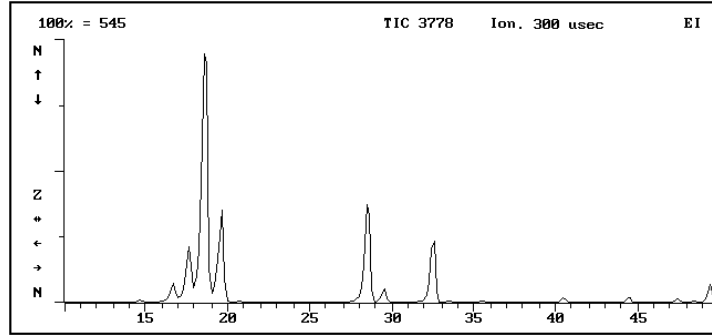

Air/Water Spectrum from a System with Excess Water Vapor and a Relatively Small Air Leak

- If the ratio of the height of the peak of mass 18 (H_2O^+) to mass 19 (H_3O^+) is about 10:1, there is little water vapor in your system.
- If the ratio of peak height of mass 18 to mass 19 is less than 10:1 but greater than 5:1, additional bakeout maybe necessary. If the water vapor is not eliminated, sensitivity and performance may be less than optimal.
- If the ratio of the peak height of mass 18 to mass 19 is less than 10:1, your system contains excess water vapor.

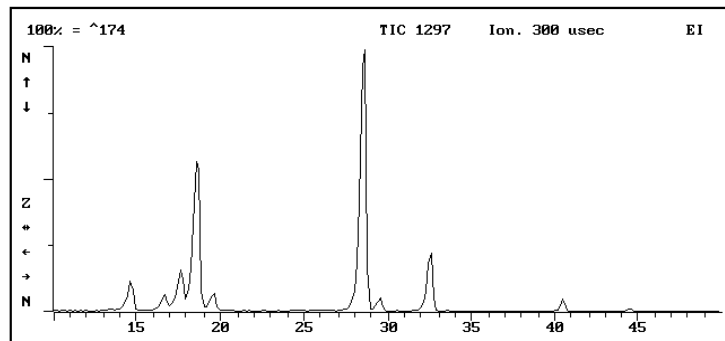

Air/Water Spectrum Obtained from a System with No Significant Air Leaks and Little Water Vapor

This spectrum is indicated by:

- The peak at mass 18 (H_2O^+) may be the base (highest) peak. This is dependent on the level of water vapor.
 - The ratio of the peak height at mass 18 (H_2O^+) to that at mass 19 (H_3O^+) is greater than or equal to 10:1.
 - The 100% counts value is significantly lower than 500.
 - The ratio of the peak height at mass 28 to that at mass 32 (O_2^+) is about 4:1.
8. If there are no air or water leaks, the following approximate values should be obtained. Note that these values vary from system to system.

100% value	TIC	18:28 ratio	19:18 ratio	28 width
<100	<1000	≈ 1:1	10 to 15%	< 1 m/z

9. Spectra observed if there is an air leak.

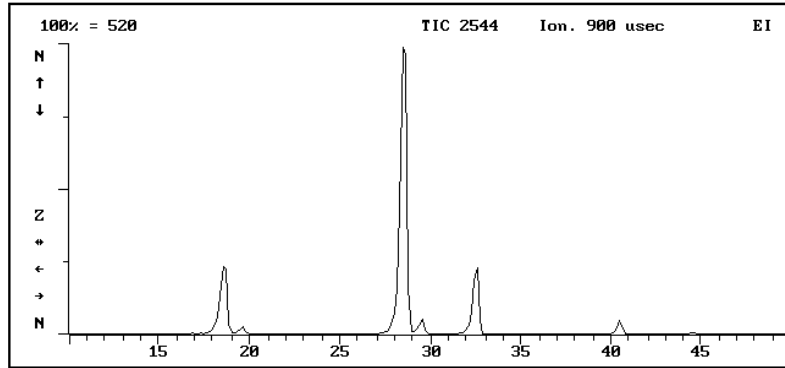

Air/Water Spectrum Obtained from a System with a Small Air Leak and Little Water Vapor

This spectrum is indicated by:

- The peak height at mass 28 is noticeably greater than that at mass 18.
- The ratio of the peak height at mass 28 to mass 32 is greater than 4:1.
- The 100% scale counts value increased to greater than 500.
- The ratio of the peak height at mass 18 to mass 19 is greater than or equal to 10:1.

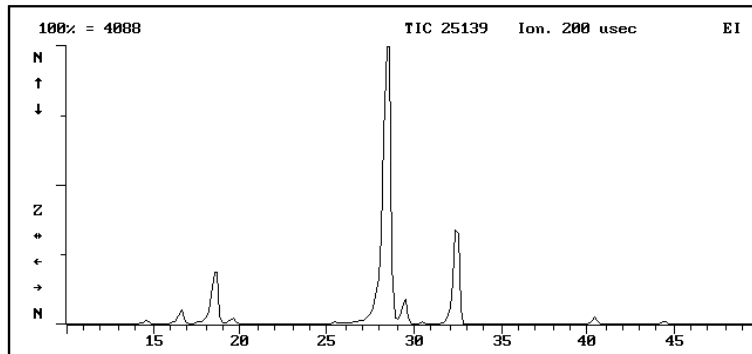

Air/Water Spectrum Obtained from a System with a Moderate Air Leak and Little Water Vapor:

This spectrum is indicated by:

- The peak at 28 starts to overload.
- The 100% counts value may be several thousand counts.
- The peak height at mass 18 is greater than that at mass 19.

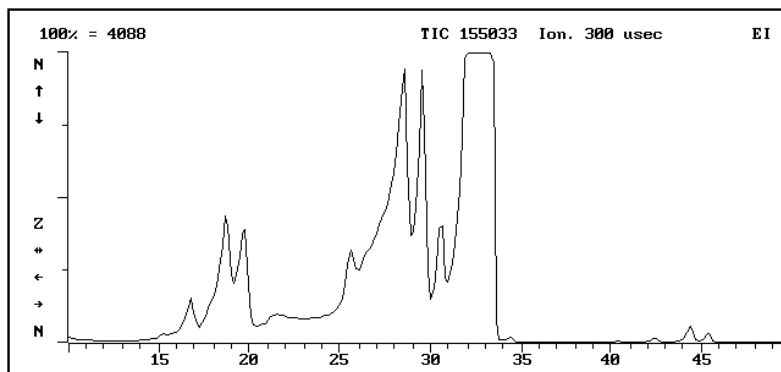

Air/Water Spectrum Obtained from a System with a Large Air Leak and Little Water Vapor:

This spectrum is indicated by:

- The peak at mass 32 is the base (highest) peak.
- The peaks at masses 18, 19, and 28 are broadened. As a leak increases, all peaks broaden and eventually become undifferentiated.

Removing High Water Levels

Causes of excessive water levels include:

- Failure to pump down for a sufficient length of time (for at least two hours, if system was vented).
- Introduction of water vapor when the ion trap is cleaned.
- Introduction of water vapor when the capillary column is replaced.
- Water vapor in the carrier gas tank.
- An atmospheric air. Often the result of high relative humidity.

High water backgrounds may be observed after venting the system especially after cleaning the trap. Several hours of bakeout may be required for the water vapor to desorb from surfaces in the vacuum system, and for the water level to drop to a stable level. Never operate MS if the mass 18 and 19 peaks are the same height (or if the air/water check shows NO). After the system has baked out sufficiently (for example, overnight) and if water vapor in the system is still detected, there may be a contamination in the carrier gas tank or an air leak.

Saturated filters on the GC may increase the air/water background. Replace the filters at regular intervals, and when moisture, or other background contamination from the GC, becomes a problem.

Using Leak Detection Gas

Use a leak detection gas such as Freon® or argon to locate leaks.

- A leak at the transfer line (the high vacuum side) should produce an immediate response.
- If the leak is coming from the GC injector, it takes about 90 seconds to see a response. (It takes about that length of time for the gas molecules to travel through the capillary column.)

If the leak is at the injector, the system does not need to be vented. Wait until all GC zones are cool before beginning. If the leak is coming from the transfer line connection, shut down and vent the system before fixing it.

NOTE: if you are using an argon leak-detection gas set the mass range from 35 to 50. If you are using a Freon leak-detection gas set the mass range from 80 to 110.

Troubleshoot leaks using argon gas as a leak detecting gas. The mass peak of interest for argon is at mass 40.

To reduce the risk of damaging the filaments or multiplier, develop a method file with the following parameters:

1. Set the electron multiplier 100 V below the 10^5 setting.
2. Turn off AGC and set the ion time to 100 μ sec.
3. Set the filament emission current to 10 μ A.
4. Set scan range from m/z of 35 to 50 (or 80 to 110).
5. Open **System Control**, and then activate the argon method for troubleshooting and turn the trap ON.

NOTE: Do not spray argon indiscriminately around the fittings. Argon diffuses very rapidly from the fitting you are testing toward a true leak. This could lead you to mistakenly identify the fitting being tested as the leak source.

To check for leaks:

- Spray a fine stream of argon on the transfer line closest to the analyzer.
- Examine the monitor for a response. If a peak at mass 40 does not appear, there is no leak.
- If a peak appears at mass 40, there is a leak. The transfer line O-ring may have particles on its surface. Shut down the system and check the O-ring.

Check the following gaskets and fittings for leaks, one at a time and in the following order. Tighten the fittings and/or flanges as needed. Wait a few seconds between subsequent applications of argon.

1. Cal gas tube fitting on the pneumatics manifold
2. Vent valve fitting on the manifold
3. Top vacuum manifold flange

Repairing Large Air Leaks

Typical sources of large air leaks in 210-MS or 220-MS are:

- Lint or damage on the manifold flange O-ring seal
- Lint or damage on the transfer line O-ring seal
- The transfer line brass nut
- The O-Ring seal between the turbomolecular pump and the manifold
- The release tabs of the analyzer that may not be locked into position

If the brass nut on the transfer line is not tight enough, ensure the nut is tight, but do not over tighten the fittings. Otherwise, you may generate an even larger leak. Then, recheck the system

If you cannot eliminate the leak, vent the system, and check the O-ring on the manifold and transfer line for particles. Wipe off the O-rings with lint-free paper.

The turbomolecular pump will probably fail to achieve its 100% speed if there is a leak or poor seal at the turbo/manifold interface. Never attempt to operate the system under these conditions.

Repairing Small-to-Moderate Air Leaks

Small-to-moderate air leaks are more problematic to find and correct than large ones. Symptoms associated with small-to-moderate air leaks include the following:

- The peak at mass 28 increases, and becoming significantly larger than the mass 18 peak.
- The air leak will probably increase the water background, particularly in humid environments. An increase in water vapor content is accompanied by a 20% or greater increase in the 19:18 mass ratio.

Checking GC Connections

NOTE: Check the GC Maintenance Section for additional information for trouble shooting leaks.

To identify and correct a leak at the connections between the capillary column and the injector or transfer line, do the following:

- Make sure that the ferrules have the correct size, for example, 0.4 mm for 0.25-mm ID columns, and 0.5 mm for 0.32 mm ID columns.
- Make sure that the ferrule on the transfer line is a graphite/Vespel® mixture. Most transfer line connection leaks occur on the high vacuum side such as around the transfer line O-ring.
 - Graphite/Vespel ferrules: tighten each ferrule one-half turn beyond finger tightness.
 - Graphite ferrules: tighten each ferrule three-quarters of a turn beyond finger tight.

- Leaks at the septum may arise from loose injector nuts or a worn septum. Insert a new septum as part of your routine GC preventive maintenance program. To reduce the level of air bleeding into the system and background from the septum material, use good quality, low-bleed septa.
- Air leaks in the GC pneumatics are the most difficult leaks to detect and eliminate, because detection gases are not particularly effective for this purpose. Tighten all fittings, and then check for leaks using a solvent such as methanol.
- Saturated filters on the GC may increase the air/water background. Replace the filters regularly or when moisture or other background material from the GC becomes a problem.

Removing the Capillary Column

To remove the capillary from the system, do the following:

1. Turn off the GC column oven and heater. Shut down and vent the MS.
2. Open the inside of the GC oven. Make sure that about 30 cm (12 in.) of the mass-spectrometer end of the capillary column is hanging freely, so that you can move the MS away from the GC without breaking the column.
3. Keep an eye on the capillary column in the GC oven as you gently slide the MS away from the GC. As you slide the MS away, take care not to allow the column to bind or kink. When you have fully withdrawn the MS from the GC, the distance separating them should be ≥ 23 cm (9 in.). The transfer line should be fully removed from the GC oven.

NOTE: Avoid contaminating the transfer line, injector, and capillary column by using clean tools and wearing clean lint-free nylon gloves. As you remove parts, place them on a clean, lint-free, unpainted surface.

4. Use the alignment tool and a 5/16 in. wrench to loosen the brass nut on the end of the transfer line.
5. Remove the capillary column from the transfer line.
6. Remove the brass nut, along with the ferrule, from the column.
7. Remove the ferrule from the nut. Discard the ferrule.
8. From inside the GC oven, pull the transfer line end of the column back into the hole in the side of the GC.

NOTE: Leave the free end of the column on the floor of the oven.

To withdraw the transfer line from the vacuum manifold, do the following:

1. Unplug the transfer line heating cable.
2. Grasp the nose of the transfer line, and then rotate it counterclockwise as you press lightly toward the manifold. Gently slide the transfer line away from the manifold.
3. Remove the nose clip, and then pull the transfer line away from the analyzer.

4. Wrap the transfer line in clean aluminum foil and place it on a clean, dry surface.
5. Cover the analyzer opening with aluminum foil.

To remove the capillary column from the GC injector, do the following:

1. Use a 5/16 in. wrench to loosen the capillary column nut that secures the column to the injector.
2. Carefully remove the nut, ferrule, and column from the injector.
3. Slide the column nut, along with the ferrule, off the end of the column.
4. Remove the ferrule from the column nut. Discard the ferrule.
5. Carefully lift the column support cage, along with the column, from the column hanger. Then, remove the support cage and column from the oven.
6. Seal the end of the column or insert the ends of the column into a septum.
7. Store the column and the support cage.

Installing New Capillary Columns

To install a new capillary column in the MS, do the following:

1. Unwind about 60 cm (24 in.) of the MS end of the column from the support cage.
2. Insert the MS end through the transfer line hole in the right side of the GC.
3. After the MS end leaves the transfer hole, put a brass nut on the column. Then slide the nut several inches down the column.

NOTE: The wide, threaded opening of the nut faces the end of the column.

4. Place a new graphite/Vespel ferrule on the column, with the taper facing the nut. Slide the ferrule, along with the nut, about 30 cm (12 in.) down the column.
5. Carefully insert the tip of the column into the nose end of the transfer line.
6. Slide the column all the way through the transfer line until the tip of the column projects a few inches beyond the transfer line tip.
7. Using a sapphire, a carbide-tipped scribing tool, or ceramic scoring wafer, score the column once lightly about 2 cm (1 in.) from its end.
8. Bend the column slightly to break it at the mark. The column should break cleanly.
9. Using a lint-free tissue dipped in methanol, carefully wipe the last 15 cm (6.0 in.) of the column.
10. Be sure to wipe toward the end of the column so that the lint-free tissue fibers do not enter the opening at the column end.

To position the column in the transfer line, do the following:

1. Install the brass nut on the end of the transfer line, but do not tighten the nut completely.
2. Keep an eye on the tip of the column and position it so that about 1 mm (1/32 in.) of the column projects from the transfer line tip.

NOTE: As you tighten the nut, the position of the column in the transfer line may change. If this happens, loosen the nut and readjust the column until about 1 mm (1/32 in.) of the column projects from the transfer line tip.

3. Grasping the transfer line securely with the alignment tool, use a 5/16-in. wrench to tighten the brass nut. Tighten the nut until snug, but do not over tighten.
4. Rotate the transfer line so that the heater cable projects downward.

To install the transfer line in the manifold, do the following and refer to the Transfer Line Exploded View on page 16:

1. Position the transfer line in the manifold, and install the clip into the holes and slots.
2. Gently push the transfer line toward the manifold, and rotate the collar in the clockwise direction until the bayonet lock engages.
3. Reconnect the transfer line heating cable to the MS.
4. Gently push the MS toward the GC, until the transfer line boot fits snugly over the collar on the side of the GC oven.

NOTE: The capillary column nut should be visible inside the GC column oven.

5. The MS is properly engaged when the bumpers on the left side of the spectrometer achieve full contact with the right side of the GC.
6. Replace the cover on the MS.

Troubleshooting the GC

NOTE: Please refer to the GC Operator's Manual for information about GC troubleshooting and diagnostics procedures not described in this section.

This section describes chromatographic troubleshooting. You will be able to see most of the problems addressed in this section by running the COLTEST mixture, part number 392027300.

The following procedure describes the chromatographic conditions and the expected results when running the COLTEST sample with a 30-m DB-5 column (0.25 mm ID, 0.25 μ m film thickness).

Running the COLTEST Sample

The COLTEST method is in this directory, <root>:\VarianWS\Service.

Setting Up the Injector Conditions

If you are using the 1079 injector, hold an initial temperature of 40 °C for 0.1 min, then ramp the temperature to 280 °C at a rate of 200 °C/min.

If you are using the 1177 injector, do the following:

1. Use an isothermal temperature of 260 °C.
2. Set up the following external event program conditions:

NOTE: If the Gas saver event" is present, it must be ON.

Time	Event 1	Injector Mode
0.00	On	Splitless
0.50	Off	Split

3. Set the splitter flow rate to 100 mL/min.

Setting Up the Column

Develop programmable column temperature program using the following:

1. Set the initial column temperature to 40 °C.
2. Hold at 40 °C for 2 min.
3. Ramp the temperature, at an initial rate of 10 °C/min to 140 °C, then at a rate of 20 °C/min to 280 °C.

NOTE: Do not hold the temperature at 140 °C.

4. Adjust the total run time to 21 min by adjusting the hold time of the last segment.

Setting Up the Transfer Line and Trap-Temperature Conditions

1. Set the transfer line temperature to 260 °C.
2. Set the trap temperature to 150 °C.
3. Set the manifold temperature to 35 °C.

Setting Up a MS Acquisition Method

To set up a MS acquisition method:

1. Set the mass range to 40 to 350 at a scan rate of 1 scan/sec.
2. Set the background mass to 39.
3. Set a filament/multiplier delay of 180 sec.
4. Set a peak threshold of 1 count.
5. Set a mass defect value of 0.
6. Specify electron ionization (EI Auto).
7. Turn cal gas OFF.

The COLTEST test mixture contains the following compounds at 1 to 5 ng/ μ L.

No.	Compound	Formula	Integer Weight	Quantitation Mass
1	decane	C ₁₀ H ₂₂	142	57
2	1-octanol	C ₈ H ₁₈ O	130	69
3	undecane	C ₁₁ H ₂₄	156	71
4	nonanal	C ₉ H ₁₈ O	142	67
5	2,6-dimethylphenol	C ₈ H ₁₀ O	122	107
6	2-ethylhexanoic acid	C ₈ H ₁₆ O ₂	144	73
7	2,6-dimethylaniline	C ₈ H ₁₁ N	121	106
8	decanoic acid, methyl ester	C ₁₁ H ₂₂ O ₂	186	74
9	undecanoic acid, methyl ester	C ₁₂ H ₂₄ O ₂	200	87
10	dicyclohexylamine	C ₁₂ H ₂₃ N	181	138
11	dodecanoic acid, methyl ester	C ₁₃ H ₂₆ O ₂	214	143
12	hexachlorobenzene	C ₆ Cl ₆	282	284

The following is a typical chromatogram for this test mixture. Note that 2, 6-dimethylphenol and 2-ethylhexanoic acid coelute normally on a DB-5 column, depending on column and injector.

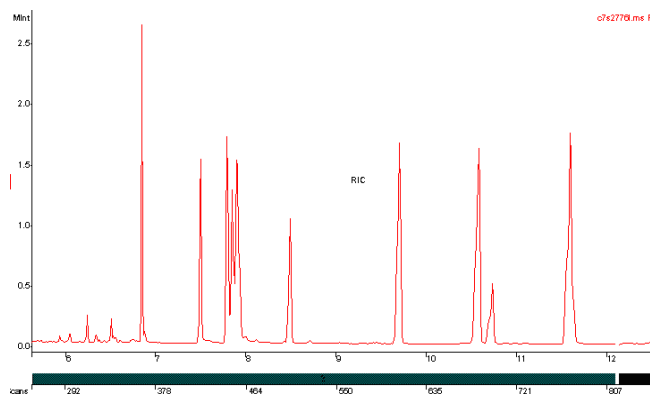

Typical Chromatogram of COLTEST Test Mixture

The following figure demonstrates the resolving power of the MS for coeluting compounds.

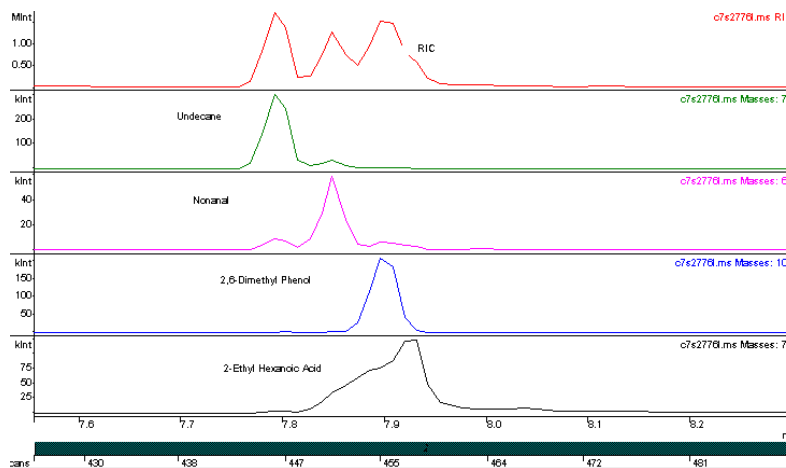

MS Resolution of Coeluting Compounds

Effectively separate the individual components in the mixture for subsequent data manipulation, such as library searches and quantitation. For details about plotting single ion chromatograms for ions specific to a single compound, please refer to the online help or section in the Software Reference manual.

Troubleshooting Chromatographic Problems

The COLTEST mixture includes polar or active compounds such as 1-octanol, 2, 6-dimethylphenol, and 2, 6-dimethylaniline. It also has some nonpolar compounds, such as decane and dodecane at approximate levels of 1 ppm in hexane. Analysis of the mixture yields information about solvent tailing, column efficiency, dead volume, active sites in the injector/column, and so on. Use the analysis to troubleshoot common chromatographic problems. The following table identifies many of the problems, and provides solutions.

Solvent Tailing or Broadening

Symptom	Solution
Poor column installation resulting in dead volume in the injector	Reinstall the column in the injector. Check the column seal with the insert in the SPI/1079 (on-column). Make sure you have a good cut on the column by examining the column under magnification. Check the 1077/1079 injector for insertion depth.
Solvent flashing in hot injector (usually 1077 or 1079)	Reduce the injection speed for the hot injectors. If possible, reduce the injector temperature. If you are using sandwich injection, reduce the solvent plug to 0.5 μ L.
Incorrect temperature control using programmable SPI or 1079 injector	A typical setting for the SPI is 20 $^{\circ}$ C below the solvent boiling point. The column temperature is set at the solvent boiling point. Hold the column at this temperature

	until SPI has finished heating (usually about 2 min).
Septum purge line plugged	Check that the septum purge flow is 2 mL/min for a 1177 or 1079. If necessary, adjust the valve setting (depending on the injector configuration).
Injector not purged properly following splitless injection	For a splitless injection, the vent flow should be at least 70 mL/min. The injector should switch to the split mode 30 to 90 sec after the injection.

Tailing Sample Peaks for Active Components

Symptom	Solution
Active sites in the injector insert or liner	Change or clean the injector insert. If necessary, use a deactivated insert.
Active sites or degraded phase present in the column	Remove the front 15 cm of the column and reinstall it. Replace the column if the retention times change, or if cutting the column does not fix the problem,

Low Response and Severe Tailing of High Boiling Point Compounds

Symptom	Solution
Injector not hot enough to vaporize high boilers	Increase the temperature of the injector
High levels of column bleed masking component peaks	Condition the column at 30 °C below its maximum operating temperature (320 °C for DB-5). Switch to a high temperature column, (e.g., the SGE HT5), if conditioning does not help.
High levels of silicone or other contamination coated on the ion trap surfaces	Clean the ion trap as outlined in the Maintenance Section. Check Contamination Table for listing of potential contaminations.
Insufficient vaporization of the higher boiling point components	Lower the injector temperature and the injection speed. Check that the graphite ferrule in the 1079 is free of cracks, and that the septum support is tight.
Trap temperature too low	Increase the trap temperature in increments of 20 °C.
Symptom	Solution
Column overload due to injection of excessive amounts of a component	Dilute the sample, or perform a split injection.
Degradation of the stationary phase	Change the column.
Carrier gas velocity too low	Increase the carrier flow rate.

Correcting Poor Resolution

An example of poor resolution is peaks that are not well separated.

Symptom	Solution
Column temperature or program is not optimized	Modify the method (e.g., slow the column ramp rate) to improve the separation
Carrier gas flow is not optimized	Decrease the carrier gas linear velocity to improve the resolution.
Column cannot separate certain species, (e.g., those with similar boiling points)	Use a more polar column.
Column stationary phase is degraded, resulting in poor efficiency	Replace the column.

Peak Size Reproducibility

Symptom	Solution
Leaking or partially plugged syringe	Visually check that the syringe is pulling up the sample. Check that the injector nut is tight. Flush the syringe with solvent. Heating the solvent in a hot injector may help if the syringe is plugged; otherwise, replace the syringe.
Leak at the septum	Replace the septum regularly and ensure that the septum nut is tight.
Improper installation of column in the injector, or a leak at the column inlet	Check the installation of the column in the injector. Tighten the capillary column nut.
Sample being absorbed by active surfaces in the injector or column	Change the injector insert. Remove the front 15 cm of the column, or replace the column.
Incomplete vaporization of sample in the injector	Increase the injector temperature. Or, increase the maximum temperature to which the injector (1079) is programmed.
1177 or 1079 splits too soon	Confirm that the switch time is chromatographically optimized.

Peak Splitting (Low Boilers)

Symptom	Solution
Sample is flashing in injector, simulating two injections.	Lower the injection temperature, or use a 1079 programmed injection.
Column temperature programming starts before 1079 has finished programming.	Increase the initial column hold time until 1079 reaches its maximum temperature, (for example, typically at 2 min.).
Column is cracked.	Re-cut and install the column.
A piece of septum is stuck in the injector insert.	Replace the insert and septum.

Extra or Unexpected Peaks

Symptom	Solution
Septum bleed, particularly during temperature programming	Use high-temperature, low-bleed septa. Make sure that the septum purge flow is set to 2 mL/min for a 1177 or 1079 injector.
Impurities from the sample vials (e.g., plasticizers present)	Confirm impurities by running a solvent blank with a new syringe. Use certified sample vials, and keep the samples refrigerated. Check contamination table.
Impurities from the carrier gas present	Install or replace the carrier gas filters.
Injector or GC pneumatics contaminated	Remove the column from the injector and bake it out at elevated temperature, (e.g., 350 °C) using a purge of at least 20 mL/min.
Impurities present in the sample	Confirm that this is indeed the case by running a blank or standard.
Solvents extract impurities from the septum.	Switch to a new septum type, lower the injection temperature, or reduce the injection volume.
Impurities present in syringe wash solvent	Use high purity grade solvents.

Retention Time Differences Between Runs

Symptom	Solution
Unstable carrier gas flow controller/regulator	Check the pneumatics for leaks. If necessary, replace the flow controller/regulator.
Column contamination or degradation	Condition or replace the column.
Injector leaks	Replace the septum at regular intervals. Check that the septum nut and capillary column nut are tight.

Documents, Parts, and Supplies

Documents

The following documents have more information about the MS:

- Software Operation Manual, part number 395414500.
- Software Reference, part number 391496300.
- MS Workstation Tutorial Manual, part number 391498800.
- Pre-Installation Instructions, part number 395414200.
- Release Notes, part number 391496201.

Parts and Supplies

The following lists part numbers and descriptions. Items are in quantities of one (1) each unless otherwise specified.

Kits, Assemblies, Boards, and Cables

Part Number	Description
393141103	USB Cable
393080001	PWA, POWER BOARD
393085001	PWA, RF GENERATOR
393074401	Cable, Controller to PWR 26 pins (Ribbon)
393074501	Cable, Controller to PWR 64 pins (Ribbon)
393011392	Replacement Spares Kit
393001001	Assembly, Analyzer Flange
393000593	Assembly, Transfer Line (115V)
393000592	Assembly, Transfer Line (230V)
393033493	Cable, Transfer Line heater (115V)
393033492	Cable, Transfer Line heater (230V)
393000891	Assembly, Vacuum Manifold (115V)
393000892	Assembly, Vacuum Manifold (230V)
393076991	Assembly, Ion Gauge
393074101	Cable, Trap Heater (60V)
393081001	PWA, Controller
393083001	PWA, Lower Manifold
393022001	PWA, Upper Manifold

Trap Components

NOTE: The Silica-Coated Spacers have a shiny, mirror like finish on the inside surface.

Part Number	Description
393055201	Gate Conductor
393055101	Gate
1492000900	Wavy Washer
393031501	Assembly, Multiplier
393053501	Spacer, Quartz
393010801	Transfer Line Wrench/Analyzer Alignment Tool
393060191	Assembly, Filament disk with wires
393054901	Filament Clip
393059191	Tip. Transfer Line (Ultra Clean)
393050001	Trap Oven
393052401	Clamping Plate
393053502	Quartz Spacer, Silica-Coated
1312200800	Nut, 8-32 X 11/32"
1499822800	Belleville Washer, Large
393053901	Thermo Well
393010904	Thermo Well O-ring
1222200606	Trap Oven screw 6-32 X 3/8
393010903	O-ring, 1.112 ID Transfer Line
393010914	Quad-ring, Viton® Manifold
393010918	Quad-ring, Viton Transfer Line

Pump Spares, Pumps, Pump Conversion Parts

Part Number	Description
393077001	DS-42 rotary vane pump, 120V
393077002	DS-42 rotary vane pump, 240V
392035800	Screen, Turbo Pump (V-81)
393031601	Cable, Turbo Controller to turbo
393031791	Turbo Controller
392051800	7' Length Tygon® Tubing
393076401	Turbo Molecular Pump (V-81)
8829953800	Premium Foreline Pump Oil (DS-42)
393847701	DS-42 Oil Mist Eliminator
8829951700	Foreline Pump Oil (1L) for DS-102
2710100200	Oil Mist Cartridge, 2/pk (DS-102)
2820043800	O-ring, Turbo Pump to Manifold
393073601	IPS module for the 225-MS

GC Spares

Part Number	Injector Type	Description
2869458001	1079 or 1177	0.4 mm Graphite / Poly Ferrules
394955100	1079 or 1177	Capillary Injector Nut
200003400	1079 or 1177	Carrier Gas Line Assembly
190015800	1079 or 1177	Ceramic Scoring Wafer
390842300	1079 or 1177	Injector Nut Wrench
7200008400	1079 or 1177	Septa Extraction Tool
8850103100	1079 or 1177	Viton O-rings, 25/pk
CR298777	1079	BTO Septa 11.5 mm, 50/pk
392534201	1079	Ferrule Insert Graphite
CR298713	1177	9 mm Septa
392611927	1177	Inlet Sleeve, Gooseneck 4 mm Open
392611936	1177	Inlet Sleeve, Gooseneck Glass Wool
391866308	1177	Screw Captive Micro Seal

Tools, Test Samples, and Other Supplies

Part Number	Description
392027000	FC-43, Reservoir (Cal Gas Bulb)
392027300	COLTEST sample
393065201	OFN test sample
392027600	Aluminum Oxide, 600 Grit
392035300	GC/MS Calibration Compound, FC-43
5550034600	Fuse, 5 x 20 mm, 0.5A
8899999000	Applicator, Cotton Tipped, pkg. 100
393010702	Solenoid, 3-way, Cal Gas
393010001	Needle Valve, Cal Gas

CI Parts/Spares

Part Number	Description
393010202	Solenoid, 2-way, CI
393059701	Restrictor, long, CI
393059601	Restrictor, short, CI
393010101	Needle Valve, CI Gas
393002291	Liquid CI Inlet Kit
393010601	CI Solenoid, 2-way, Chemrez

Varian Service

If you are unable to resolve a problem with your MS, call a Varian Customer Support Representative. When you call, you must provide the following information:

- MS serial number, which is inside the front panel.
- Installed options.
- Diagnostics test results.

If you are having problems with the gas chromatograph, provide the following information:

- GC model.
- AutoSampler model, if any
- Type of injector in use.
- Cryogenics (if applicable).
- Information about your GC column, (for example, the manufacturer, bonded phase, film thickness, and ID and length).

If you are having problems with your computer or software, provide the following information:

- Computer manufacturer and model.
- Windows version.
- Mouse driver version.
- Printer manufacturer and model.
- Network configuration.
- Printouts of your autoexec.bat and config.sys files.
- MS Workstation software version.

Observe the following guidelines when describing the problem to the Customer Support Representative:

- Tell the service representative which part of the software, you were using when the problem occurred.
- Tell the Support Representative which troubleshooting routines you used.